

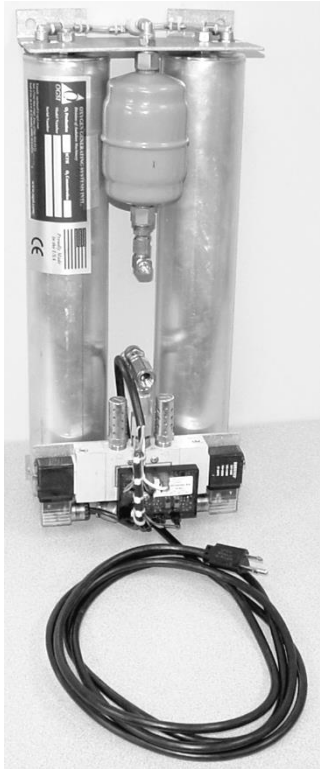

OG-15 OEMC and OG-20 OEMC

Installation, Operation and Maintenance Manual



Oxygen Generating Systems Intl. (OGSI)

Division of Audubon Machinery Corporation

814 Wurlitzer Drive, North Tonawanda, New York 14120 USA

Tel: (716) 564-5165 **Toll Free:** (800) 414-6474 **Fax:** (716) 564-5173

E-mail: ogsimail@ogsi.com

Website: www.ogsi.com

Part # 9000000-006

US \$25.00

Page left intentionally blank

Table of Contents











Topic	Page Number
Using this Manual	1
Initial Inspection	2
Warranty Information and Liabilities	3
Safety Guidelines	5
➤ Operating	5
Product Information	6-18
➤ Features and Applications	6
➤ PSA Technology	8
➤ Components	9
➤ Process Flow Description	16
➤ Specifications	17
Safety Precautions	19
Pre – Installation	20
Required Operating Conditions	21
Set-up and Installation	22
Operating Instructions	22
Troubleshooting Guide	23
Preventive Maintenance	24
Technical Service Assistance	25
Appendix	I-VIII
➤ Certificate of Compliance	I
➤ Spare Parts List	II
➤ Oxygen Cleaning Procedure	III
➤ Units of Measurement	VII
➤ Maintenance Log	VIII

©2014, *OGSI*. All rights reserved. *OGSI* is a registered trademark.
This publication may not be reproduced in part or whole without written permission of *OGSI*.

Using this Manual

This manual is intended as a guide for operators/users of *OGSI* Oxygen Generators and Oxygen Generating Systems. It includes information on our warranty policy, features, functions, applications, proper set-up and installation, operation and preventive maintenance of our products.

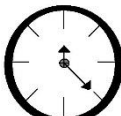
The following symbols are used throughout the manual:

 <p>Information (Do not use product before reading the manual)</p>	 <p>Electrical Hazard</p>
 <p>Sound</p>	 <p>Fire Hazard</p>
 <p>No Smoking</p>	 <p>Warning</p>
 <p>No Open Flames</p>	 <p>Power ON/OFF</p>
 <p>Flow Meter</p>	 <p>Timer</p>
 <p>No Oil</p>	 <p>Not Connected to Outlet</p>



Initial Inspection

The box should be opened and inspected immediately upon delivery. Unpack the unit at once and perform a visual inspection to determine if it is dented, bent or scratched. Also check to make sure the power cord is attached and has not been damaged in any way during shipment.

If for any reason the unit should need to be returned in the future, the original box is the best way to ship it back to the manufacturer. Claims of damage due to freight handling can only be filed by you, the consignee, as **OGSI** shipping terms are Free On Board (FOB), North Tonawanda, NY USA. This means that once the equipment leaves our dock you are the owner of it. **OGSI** has no legal claim to make against any shipping company for damage.

At **OGSI**, we are committed to using shipping companies with good reputations for taking care in the overall handling of freight and providing service in the event of damage. In our experience, we have found *United Parcel Service (UPS)* to be a poor carrier choice for equipment of this size and weight. Although they will accept and deliver it, we have often encountered problems with the way they handle the systems, and recommend other freight carriers be used. (E.g. Federal Express (FedEx) – Insured shipment)

Warranty

Oxygen Generating Systems Intl., being a division of Audubon Machinery Corporation (hereinafter **OGSI**), provides a warranty on its products (the “Products”) against defects in material and workmanship, under normal use and operation, to the extent set forth in this Warranty.

THIS WARRANTY IS THE SOLE AND EXCLUSIVE WARRANTY OF **OGSI** WITH RESPECT TO THE PRODUCTS AND IS IN LIEU OF ALL OTHER WARRANTIES EXPRESSED OR IMPLIED ALL OF WHICH ARE HEREBY DISCLAIMED TO THE FULLEST EXTENT PERMITTED BY APPLICABLE LAW. WITHOUT LIMITING THE GENERALITY OF THE FOREGOING DISCLAIMER AND EXCEPT AS OTHERWISE SET FORTH IN THIS WARRANTY, **OGSI** DISCLAIMS ALL WARRANTIES OF MERCHANTABILITY WITH RESPECT TO THE PRODUCTS AND ALL WARRANTIES OF FITNESS FOR A PARTICULAR PURPOSE. THE WARRANTY OF **OGSI** AS SET FORTH HEREIN IS FOR THE BENEFIT OF THE ORIGINAL USER OF THE PRODUCTS AND IS NOT TRANSFERABLE WITHOUT THE PRIOR EXPRESS WRITTEN CONSENT OF **OGSI**.

The **OGSI** Warranty provides the following:

- 1) **OGSI** shall repair or replace the Products free of charge to the original user where defects in the material and/or workmanship are evident at the time of delivery. Such replacement of the Products does not include damages incurred in shipping the Products. If shipping damage is evident, the original user should contact the shipper immediately. **OGSI** will pay for shipping the Products to the original user as well as returning damaged/defective Products to **OGSI**. Once the Products are repaired, **OGSI** will ship the Products back to the original user and cover all costs incurred in shipping.
- 2) **OGSI** shall repair or replace the Products (excluding filter elements and sieve material) free of charge to the original user where defects in material and/or workmanship become evident between the time of delivery to the original user and one (1) year from the date of delivery to the original user. **OGSI** will pay for shipping the Products to the original user as well as returning damaged/defective Products to **OGSI**. Once the Products are repaired, **OGSI** will ship the Products back to the original user and cover all costs incurred in shipping. In no event shall **OGSI** have any responsibility or liability for the cost of labor for the removal of component parts or equipment that constitute part of the Products, packaging of the component parts or equipment that constitute part of the Products or the re-installation or replacement of the component parts or equipment that constitute part of the Products.
- 3) The warranty provided by **OGSI** to the original user covers parts and equipment specifically manufactured by **OGSI** and used as components or equipment that constitute part of the Products. The warranty on parts or equipment manufactured by third parties and included as part of the Products (*e.g., air dryers, air compressors, oxygen compressors, instrumentation, etc.*) is limited to the respective original warranties of such third parties.

Note: A *Return Authorization Number* must be obtained from **OGSI** prior to the return shipment of the Product or any component parts or equipment of the Products.

The *Return Authorization Number* must be visibly written on the outside of the package of the returned Products, component parts or equipment as applicable or **OGSI** will not accept the return.

Note: A *Credit Certificate* will be created for all Warranty Exchange transactions. **OGSI** will provide the *Credit Certificate* with an invoice at the time of shipment to the original user. The *Credit Certificate* must be included in the package to **OGSI** with the returned products within 30 days of the date of the invoice. Failure to return Warranty Exchange Products to **OGSI** within 30 days will make the Warranty Exchange process void and payment for Products will be billed and due on receipt.

Note: The warranties of **OGSI** as set forth herein shall also become null, void and not binding on **OGSI** if a defect or malfunction occurs in the Products or any part of the Products as a result of:

- a) A failure to provide the *Required Operating Conditions* for the Products
(See page 21)
- b) Repair, attempted repair, adjustment or servicing of the Products, or any component parts or equipment that constitutes part of the Products by anyone other than an authorized representative of **OGSI**. The authorized service representative must obtain prior approval from **OGSI**'s Service Manager before performing any warranty work.
- c) External Causes (e.g. flood, hurricane, tornado, fire, any natural disaster, or any event deemed an act of God).

Molecular Sieve Replacement:

The breakdown of the molecular sieve inside the generator (dusting of the sieve) only occurs if excess water/oil is entrained in the feed air stream. Under no circumstances is the molecular sieve covered under any warranty by **OGSI**. If sieve dusting occurs on your machine, check the air compressor, air dryer and filter elements.

Other Matters:

OGSI is not liable for any special, indirect, punitive, economic, incidental or consequential losses or damages including without limitation, loss of use, malfunction of **OGSI** products, replacement oxygen charges, delays or lost savings related to the Products or otherwise even if **OGSI** shall have been advised of the possibility of such potential losses or damages.

Limits of Liability

OGSI Oxygen Generator products shall not be used for breathable or medical oxygen applications, unless they are assembled with the appropriate support equipment, tested, and operated in compliance with either American, Canadian or ISO norms for hospital oxygen systems.

Safety Guidelines



Operating

Although oxygen itself is not combustible, it can be very dangerous. It greatly accelerates the burning of combustible materials.



Precautions should be taken to avoid a fire in the area of the unit.



Smoking should not be permitted in the area where the unit is located.



All oxygen connections and hoses should be kept clean and free of grease, oil and other combustible materials.



Valves controlling oxygen flow should be opened and closed slowly to avoid the possibility of fires or explosions.



Do not attempt to modify or enhance the performance of a unit in any way.

When bleeding a tank or line, stand clear and do not allow oxygen to embed itself within clothing. A spark could ignite the clothing violently.

Product Information



Features and Applications

The *OGSI* Model **OG-15 OEMC** and **OG-20 OEMC** units extract oxygen from the atmosphere using Pressure Swing Adsorption (PSA) technology. They concentrate oxygen up to **93% (± 3%)** purity which can be applied in various ways.

Features

Easy to Use

- Just connect to an electrical outlet and a regulated air supply source.

Dependable

- Its filtration system, Zeolite sieve, storage tank, and flow control system are designed for **24/7** operation.

Durable

- The anodized aluminum sieve beds are fitted with custom aluminum end caps for years of reliable service.

Portable

- Weighing at just **17 lb (8 kg)** and **20 lb (9 kg)** respectively, the **OG-15 OEMC** and **OG-20 OEMC** are industrial strength units.

Safe

- **OG-15 OEMC** and **OG-20 OEMC** have a built-in safety relief valve to prevent pressures above **55 psi**. The **OG-15 OEMC** and the **OG-20 OEMC** deliver an optimal flow of oxygen up to **12 psi (0.83 bar)** and **20 psi (1.4 bar)** respectively.

Economical

- Oxygen is free! The **OG-15 OEMC** and **OG-20 OEMC** units eliminate the unnecessary costs involved in transportation, storage and cylinder rental. The **OG-15 OEMC** and **OG-20 OEMC** units use less than **0.3 W** of electricity to deliver up to **15 ft³** and **20 ft³** of oxygen per hour respectively. These products are cost-effective and energy-efficient.

Applications

The **OG-15 OEMC** and **OG-20 OEMC** can be used in various applications. A few examples are given below.

Hyperbaric Oxygen Therapy (HBOT)



Fish Farming and Aquaculture



Laundromats



Bottled Water Manufacturing



Waste and Water Treatment



Pressure Swing Adsorption (PSA) Technology

An *OGSI* Oxygen Generator is an on-site oxygen generating machine capable of producing oxygen on demand in accordance with your requirements. In effect, it separates the oxygen (21%) from the air it is provided and returns the nitrogen (78%) to the atmosphere through a waste gas muffler. The separation process employs a technology called **Pressure Swing Adsorption (PSA)**. At the heart of this technology is a material called Molecular Sieve (Zeolite). This sieve is an inert, ceramic-like material that is designed to adsorb nitrogen more readily than oxygen. Each of the two beds that make up the generator contains this sieve. The process is described below.

Stage 1

Compressed air is fed into the first molecular sieve bed. Nitrogen is trapped, while oxygen is allowed to flow through.



Stage 2

When the sieve in the first bed becomes full of nitrogen, the airflow is then directed into the second bed.



Stage 3

As the second bed separates the oxygen from the nitrogen, the first bed vents its nitrogen into the atmosphere.

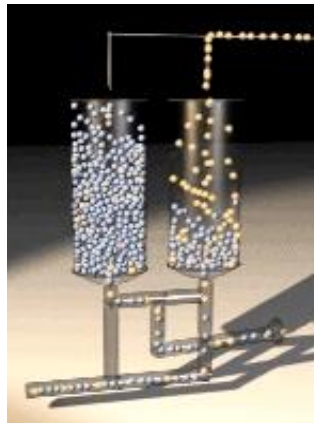

Stage 4

Compressed air is once again fed into the first bed and the process is repeated continuously. A constant flow of oxygen is produced.

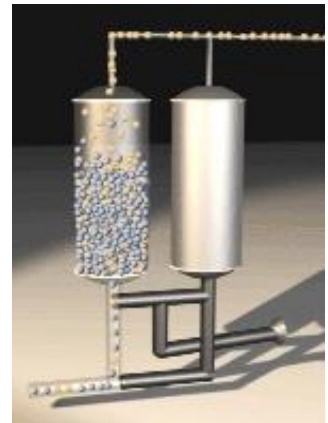

This air separation process is reliable and virtually maintenance-free. The molecular sieve will last indefinitely, as long as it does not become contaminated with water or oil vapors. This is why regular filter element replacement is crucial to trouble-free operation. The filter elements are inexpensive and require semi-annual maintenance.

Components

Front View

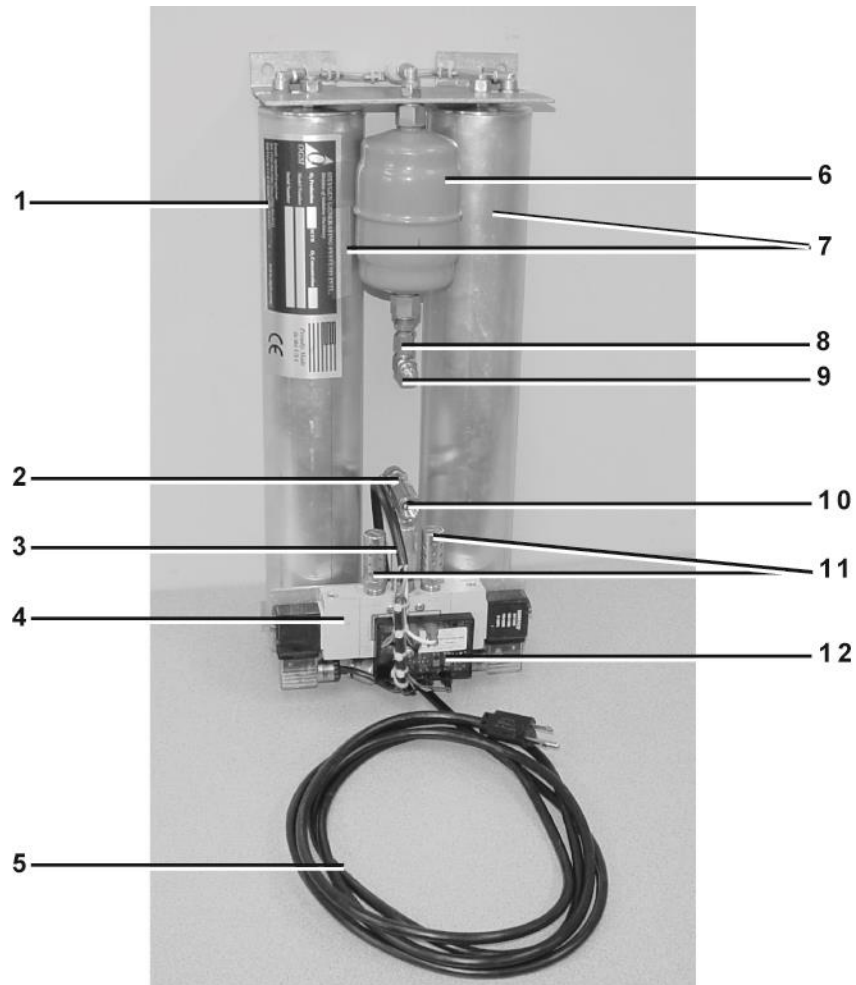

1. Serial Number Tag

2. Safety Relief Valve

3. Inlet Check Valve

4. Valve Block

5. Power Cord

6. Oxygen Receiver Tank

7. Sieve Bed

8. Outlet Orifice

9. Oxygen Outlet

10. Compressed Air Inlet

11. Exhaust Muffler

12. Circuit Board

Top View

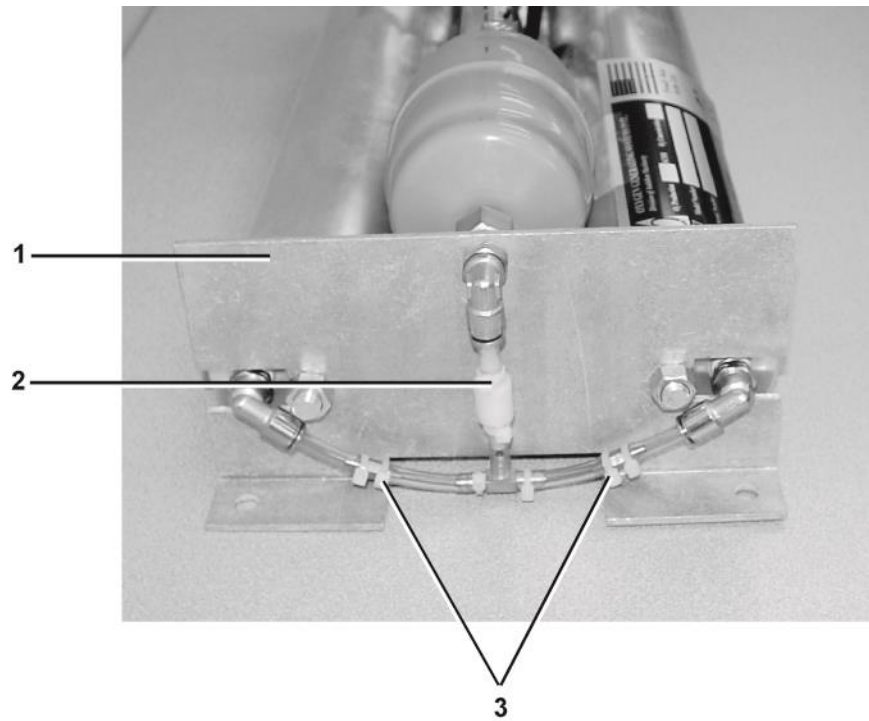

- 1. Top Mounting Plate**
- 2. Outlet Check Valve**
- 3. Purge Orifice**

Bottom View

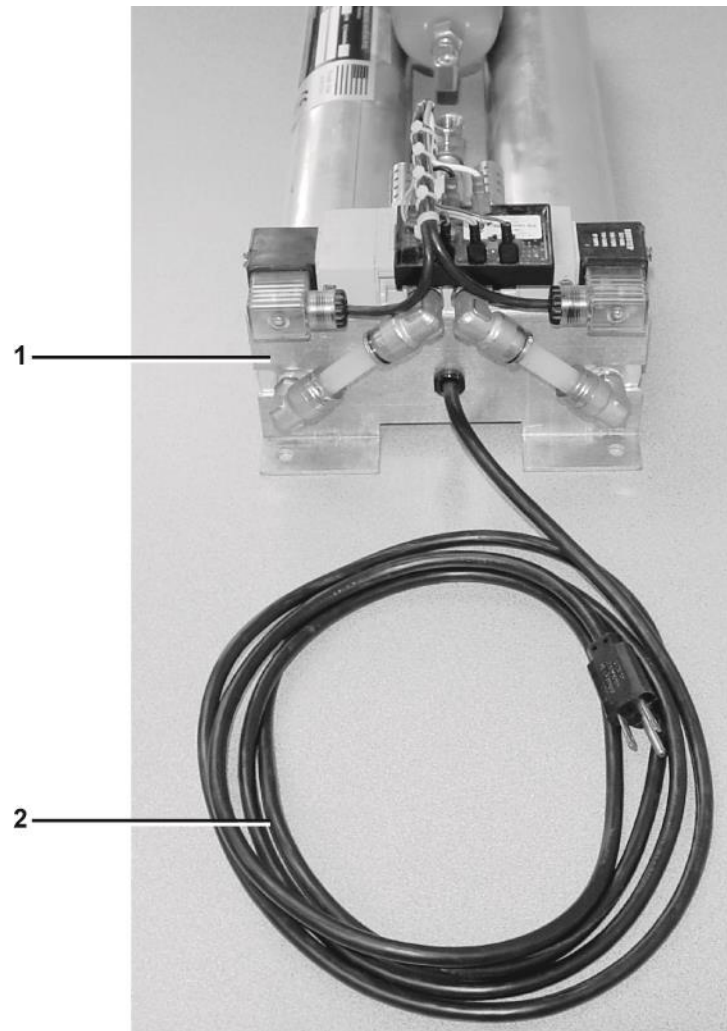

1. Bottom Mounting Plate

2. Power Cord

OG-20 OEMC

Front View

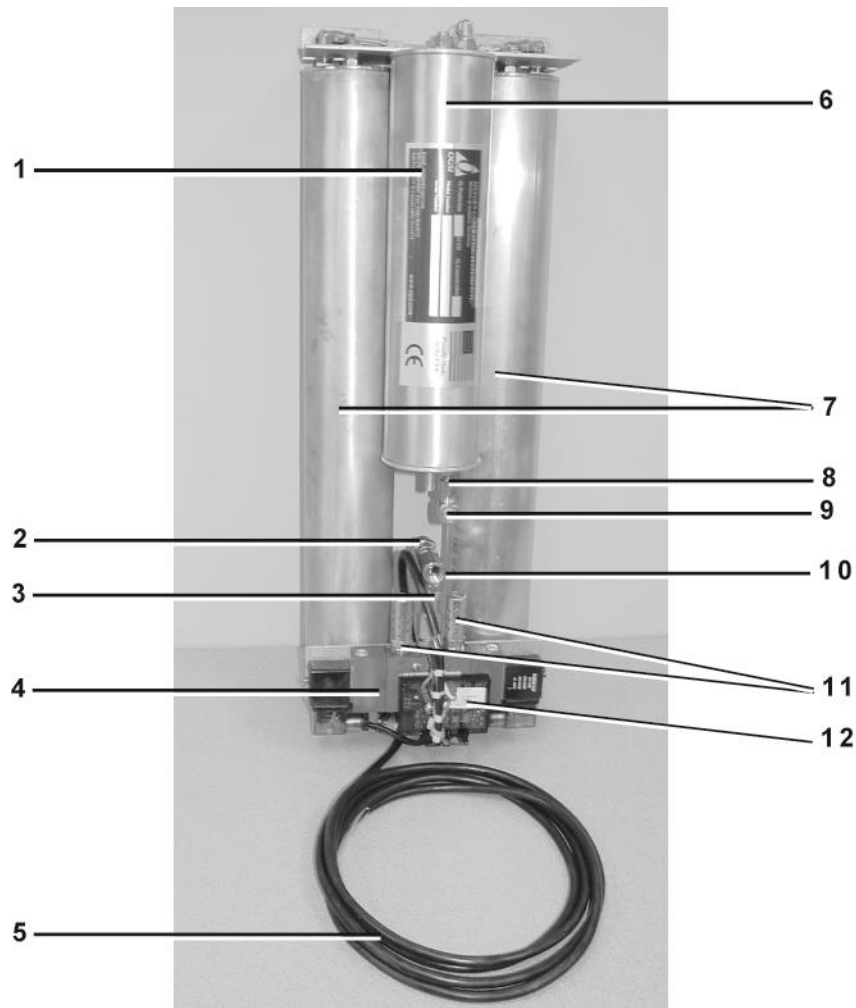

1. Serial Number Tag

2. Safety Relief Valve

3. Inlet Check Valve

4. Valve

5. Power Cord

6. Oxygen Receiver Tank

7. Sieve Bed

8. Outlet Orifice

9. Oxygen Outlet

10. Compressed Air Inlet

11. Exhaust Muffler

12. Circuit Board

Top View

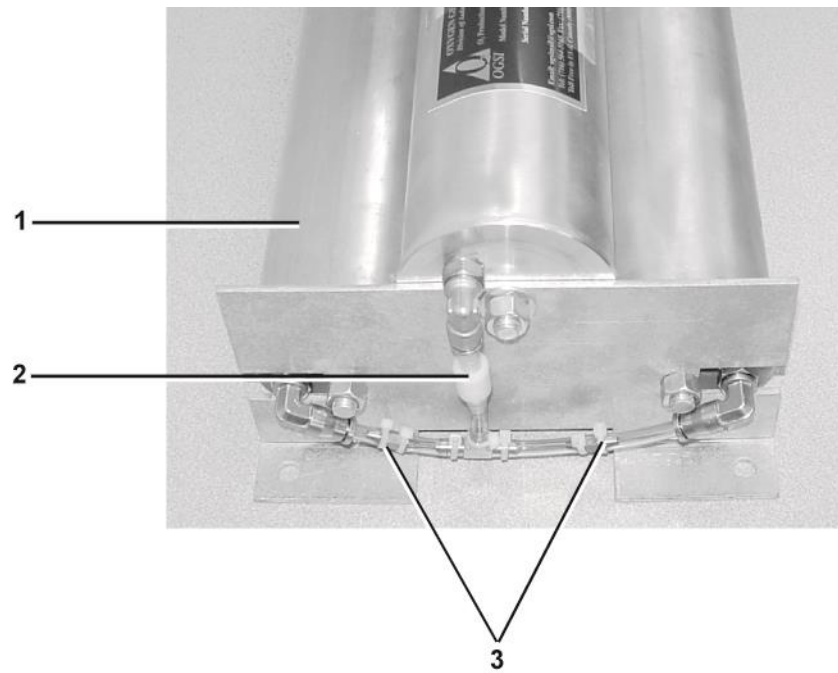

1. Top Mounting Plate
2. Outlet Check Valve
3. Purge Orifice

Bottom View

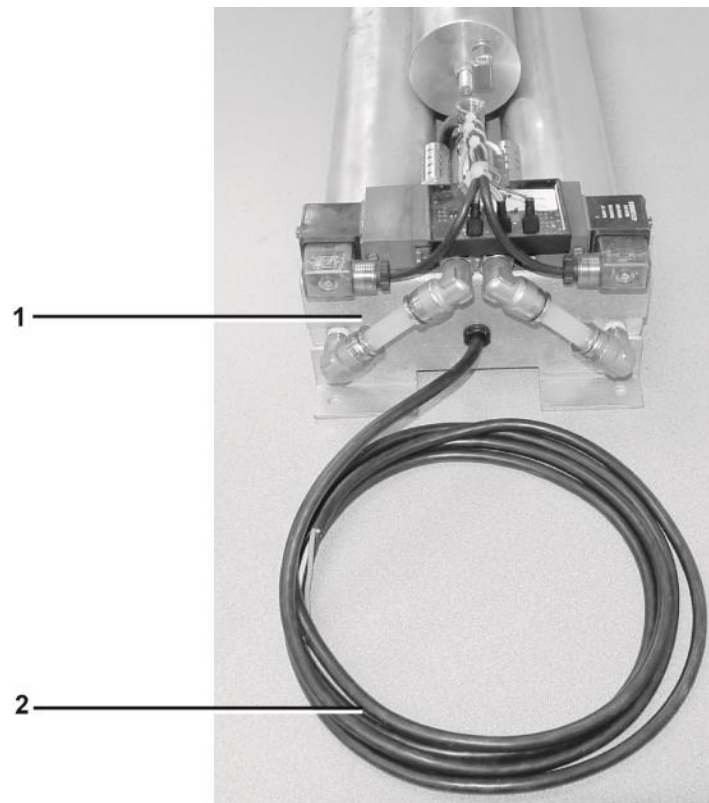

1. Bottom Mounting Plate

2. Power Cord

Components Description

Circuit Board	The circuit board controls the operation of the flow controlling valves. While one valve coil is energized, the other is not.
Sieve Beds	These beds contain the molecular sieve that performs the air separation process. They are spring loaded to prevent settling and should never need to be opened. If the sieve becomes contaminated, the beds can be easily replaced.
Solenoid Valve	The solenoid valve controls the direction of airflow in the machine. This controls the feed and waste cycles for each bed. They direct feed air to each bed during oxygen production and waste nitrogen through the muffler to regenerate the sieve. The cycle continues while the unit operates.
Power Cord	The power cord used on 115 VAC/60 Hz electrical systems comes with a three-pronged ground fault protected plug. For 230 VAC , a plug of local configuration will need to be installed by the end-user.

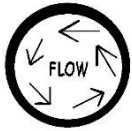

Process Flow Description

User-supplied air should be filtered and regulated to the proper pressure feeding into the **OG-15 OEMC/OG-20 OEMC**. It is then directed into one of the two sieve beds. As the air enters the bed, the nitrogen is adsorbed by the sieve and the oxygen passes through as product gas to the storage tank. Each bed produces oxygen until the sieve in that bed is saturated with nitrogen. When this occurs, the feed airflow is directed to the other bed, which continues the production process. While the second bed is producing oxygen, the first bed is releasing into the atmosphere the nitrogen it adsorbed, under very low pressure through a waste gas muffler.

Pressure, flow rate and oxygen purity are all interrelated properties. Any attempt to increase pressure or flow rate will cause a decrease in one (or both) of the remaining two properties. The rated production capacity of this machine is **15 SCFH (0.4 Nm³/h)** or **7 LPM** at **12 psi (0.83 bar)** for **OG-15 OEMC** and **20 SCFH (0.5 Nm³/h)** or **10 LPM** at **20 psi (1.4 bar)** for **OG-20 OEMC**. Oxygen purity will suffer in any overdraw conditions.

Unit Specifications: OG-15 OEMC

Performance

Oxygen Volume	15 SCFH @ 12 psi 7 LPM or 0.4 Nm ³ /h @ 0.83 bar
Oxygen Pressure	1 – 12 psi (0.83 bar)
Oxygen Purity	93% (± 3%) [United States Pharmacopeia (USP) XXII oxygen 93% Monograph]
Oxygen Dew Point	- 60° F (-51°C)
Feed Air Requirement	4 SCFM @ 20-40 psi (6.3 Nm ³ /h @ 1.4 - 2.8 bar)
Response Time	Approximately 2 minutes to attain maximum purity after initial start-up or extended shut-down

Physical

Oxygen Outlet Fitting	1/8" FNPT Bulkhead
Air Inlet Fitting	1/4" FNPT Bulkhead
Sound Levels	35 dBA @ 1 m
Dimensions	8 x 8 x 19 in (W x D x H) 21 x 21 x 49 cm (W x D x H)
Weight	17 lb (8 kg)

Power Requirement

Standard (Domestic) Optional (International)	115 VAC, 60 Hz, Single Phase 0.2 A 230 VAC, 50/60 Hz, Single Phase, 0.1 A
---	--

Unit Specifications: OG-20 OEMC

Performance

Oxygen Volume	20 SCFH @ 20 psi 10 LPM or 0.5 Nm ³ /h @ 1.4 bar
Oxygen Pressure	1 – 20 psi (1.4 bar)
Oxygen Purity	93% (± 3%) [United States Pharmacopeia (USP) XXII oxygen 93% Monograph]
Oxygen Dew Point	- 60° F (-51°C)
Feed Air Requirement	4.9 SCFM @ 20-40 psi (7.7 Nm ³ /h @ 1.4 - 2.8 bar)
Response Time	Approximately 2 minutes to attain maximum purity after initial start-up or extended shut-down

Physical

Oxygen Outlet Fitting	1/4" FNPT Bulkhead
Air Inlet Fitting	1/4" FNPT Bulkhead
Sound Levels	35 dBA @ 1 m
Dimensions	8 x 8 x 23 in (W x D x H) 21 x 20 x 59 cm (W x D x H)
Weight	20 lb (9 kg)

Power Requirement

Standard (Domestic)	115 VAC, 60 Hz, Single Phase 0.2 A
Optional (International)	230 VAC, 50/60 Hz, Single Phase, 0.1 A

Safety Precautions



It is very important that you read the precautions below and make yourself aware of the hazards of oxygen in general. While it can be handled and used very safely, it can also be mishandled or applied incorrectly causing dangerous situations.



Oxygen is a fire hazard. It can be very dangerous as it vigorously accelerates the burning of combustible materials. To avoid a fire and/or the possibilities of an explosion; oil, grease or any other easily combustible materials must not be used on or near the unit. **DO NOT SMOKE NEAR THE UNIT.** The unit should be kept away from heat and open flames. Individuals who have experience handling oxygen systems should become the designated operators of the unit within your facility.



In crucial applications, it is important to have a backup supply of oxygen since the unit does not come with any reserve storage tank and requires electrical power to operate. ***Therefore, during power outages, oxygen will not be produced.***

Do not use extension cords to bring power to the generator. The current drawn into the unit is high and could overheat some extension cords. It is also important to use only a properly grounded electrical outlet.

High pressure oxygen may present a hazard. Always follow proper operating procedures, and ***open valves slowly.*** Rapid pressurization may result in operator/user injury. Safety glasses and hearing protection are required when venting oxygen under high pressure.

Ensure that the oxygen outlet stream is not directed toward anyone's clothing. Oxygen will embed itself in the material and one spark or hot ash from a cigarette could violently ignite the clothing.



Pre-Installation

Before installing the **OGSI OG-15 OEMC/OG-20 OEMC**, it is necessary to consider the location, space available and power supply for the generator.

1) Locating the **OG-15 OEMC/OG-20 OEMC**:

- The unit should be located in an area that is indoors and remains between **40°F (5°C) and 100°F (38°C)**. **Setting up the machine outdoors or in an area that is not normally within this temperature range will void the OGSi Warranty.**
- The machine must be located within reach of an air supply line, as this machine requires an external pre-existing source of pressurized air.
- To use **OG-15 OEMC/OG-20 OEMC** with another application, please consult **OGSI**.

2) Space Available for the **OG-15 OEMC/OG-20 OEMC**:

- If the **OG-15 OEMC/OG-20 OEMC** is going to be set up in a room that is small, (less than **1000 ft³ or 28.3 m³**), that room should be well ventilated (at least **5** air changes in the room per hour). The unit will be discharging nitrogen into the atmosphere of the room and a nitrogen build up could be dangerous to people entering the room. If the unit is placed in a small closet, the air in that closet will become enriched with nitrogen. As the unit continues to operate, it would become more and more difficult for it to separate the oxygen from the air because oxygen will make up a smaller and smaller fraction of the air that is fed into the unit.

3) Power Supply for the **OG-15 OEMC/OG-20 OEMC**:

- The unit should be positioned within **8 ft (2.2 m)** of the electrical outlet that will power it. **It is also very important for this reason NOT to use any extension cords with the unit.** They could overheat and melt, possibly causing a fire. The electrical outlet system to which the **OGSI** unit is connected should be used exclusively for that purpose and no other electrical appliances should be connected to it.



Required Operating Conditions

Location of Machine:

This standard oxygen generating system is intended for use indoors in a commercial or light industrial setting.

Feed Air/Ambient Air Quality:

The life of any PSA oxygen generator is directly related to the air quality that is fed into it. Hot, humid, dirty, oily air deteriorates and degrades the performance of the molecular sieve. In order to preserve the effectiveness and extend the life of the oxygen generator, precautions must be taken to ensure that the air provided is cool, dry, clean and oil-free.

It is advisable to operate the unit in an air-conditioned or a well-ventilated area. The room should also be free of toxic gases and high concentrations of hydrocarbons, especially carbon monoxide. Humid, oily areas should be avoided as installation sites as much as possible.

Ambient Air Temperature:

The machine is designed for use over a temperature range of **40°F to 100°F** (**5°C to 38°C**). Since hot air has the ability to hold more water in the form of humidity than cool air, operating the unit in hot areas will reduce the effective life of the molecular sieve.

Note: Operation outside of this temperature range will not be warranted by *OGSI*.

Electrical Power:

On U.S. models, the power for the control circuitry of the oxygen generator is a single-phase electrical supply of **115 VAC** and about **0.2 A** at a frequency of **60 Hz**.

This equates to approximately **0.3 W** of power. It is required that a **0.5 A** circuit be dedicated to each **OG-15 OEMC/OG-20 OEMC** unit. The unit must be connected to this circuit using only the supplied power cord, and without the use of additional extension cords.

Feed Air Requirements:

An incoming air pressure of **4 SCFM or 6.3 Nm³/h** for **OG-15 OEMC** and **4.9 SCFM or 7.7 Nm³/h** for **OG-20 OEMC** at **20-40 psi (1.4 - 2.8 bar)** is required for proper functioning of this machine. The air should be cool, dry and clean, filtered to remove any contaminants such as dust particles and moisture. It is recommended that it meet the requirements of *ISO8573.1 Class 1.4.1*.



Set-up & Installation

Although every **OG-15 OEMC/OG-20 OEMC** unit is thoroughly tested and checked before it is shipped from our facility, the following steps are necessary to ensure that none of the internal components have been damaged during shipment. This check should take less than five minutes to perform. (Refer to ***Initial Inspection*** ' on Page 2 before reading the instructions below)

Make a visual inspection of the machine and make sure all parts are properly connected. (Refer to ***Components*** ' section)



Connect the unit into a grounded electrical outlet. A receptacle plug of local configuration will need to be attached first if the machine has been shipped outside North America.



Operating Instructions

Start-up

Once the system has been installed in accordance with the set-up and installation instructions, it may be operated. The following steps should provide some direction. Please keep in mind that this system produces medical grade oxygen however the system is not intended to be used a medical device.

Connect the oxygen outlet to the application.



After connecting it to an electrical outlet and a regulated air supply source, wait for **2** minutes for the unit to come up to maximum purity.

Call the ***OGSI Technical Service Department*** at (800) 414-6474 (toll free number in USA and Canada) or (716) 564-5165 if system does not work.

Troubleshooting Guide

Problem	Sign	Cause	Solution
Dusting of Sieve Beds	White powder visible in the machine or very high air pressure levels	<ul style="list-style-type: none"> • Contaminated sieve • Moisture in air 	<ul style="list-style-type: none"> • Repack the sieve beds. • Clean valves and mufflers. • Make sure dry air is being fed to the machine.
Valves Sticking	Air pressure levels too high	Dusting of sieve or machine filled with dirt and dust due to air filters not being replaced	Remove valve block from machine and clean valves and spools completely.



Warning Signs

Low Oxygen Pressure	This may be a result of a leak in the system. Use a leak testing solution to locate and repair any air leaks.
The machine has run for 30 minutes and purity has not yet been reached	This may be a result of a leak in the system. Use a leak testing solution to locate and repair any air leaks.
Oxygen purity has fallen below acceptable limits	This may be an indication of a leak within the system. Use a leak testing solution to locate and repair any leaks.

Preventive Maintenance

Power Cord:

The power cord should be occasionally washed down with a sponge or clean rag and some soapy water. Avoid the use of ammonia or other strong chemical based cleaning solvents. This prevents dust and dirt from building up on the cord.

Valve Replacements:

The best method to address this issue is to return the unit to *OGSI* or to an authorized service center for repair, the same procedure as compressor repairs.

Technical Service Assistance

It is our intention to provide complete customer satisfaction. This manual is one way in which we hope to provide you with technical assistance.

If you do not find what you need in this manual or you have other questions about this equipment, please feel free to contact us directly. We look forward to serving your oxygen needs and invite your inquiries. We will respond to you as promptly as possible.

You can reach **OGSI** through the following means:

- **By Telephone (Within the United States and Canada):**
(800) 414-6474 - Our toll free number (Within USA and Canada only)
(716) 564-5165 - Our direct number
- **By Telephone (Outside the United States):**
Your local International Access Code (usually **0** or **00**), followed by
The Country Code for the U.S. which is (**1**), followed by
Our Area Code and Number (**716**) **564-5165**
- **By Automated Voicemail:**
(716) 564-5165
- **By Fax (Within or outside the United States):**
(716) 564-5173
- **By E-Mail or Website:**
ogsimail@ogsi.com
<http://www.ogsi.com>
- **By Mail:**
OGSI
814 Wurlitzer Drive
North Tonawanda, New York 14120 USA
- **By UPS, FedEx or Common Carrier: (Address to return shipments)**
OGSI
814 Wurlitzer Drive
North Tonawanda, New York 14120 USA

*Technical service personnel are available from 8:00 AM to 5:00 PM EST (GMT - 5).
We also have a list of Distributors and Authorized Service Agents available upon request.*

Customer Satisfaction Survey

Help us serve you better. Please take our Customer Satisfaction Survey at www.ogsi.com

Page left intentionally blank

Appendix

Page left intentionally blank



OG-15/OG-20 OEMC CERTIFICATE OF COMPLIANCE

GENERATOR/TESTING INFORMATION

Technician _____ Serial No. /Mod _____ Date ___/___/___

Hours ___ Purity ___% Regulated Air Pressure: _____ Outlet Pressure _____ psi

Flow Meter Setting ___ SCFH Voltage 115 V 230 V Temperature ___ °F Humidity ___%

Oxygen Outlet Orifice _____

QUALITY CONTROL INFORMATION

	PASSED		PASSED
Valve	<input type="checkbox"/>	Left Side Sieve Bed	<input type="checkbox"/>
Elbows	<input type="checkbox"/>	Top Elbow	<input type="checkbox"/>
Purge Loop/O2 Out	<input type="checkbox"/>	Top O ring	<input type="checkbox"/>
Orifices	<input type="checkbox"/>	Bottom Elbow	<input type="checkbox"/>
Barbed Tee	<input type="checkbox"/>	Bottom O ring	<input type="checkbox"/>
Check Valves	<input type="checkbox"/>	Right Side Sieve Bed	<input type="checkbox"/>
Bottom Bed Tubes	<input type="checkbox"/>	Top Elbow	<input type="checkbox"/>
Secure	<input type="checkbox"/>	Top O ring	<input type="checkbox"/>
Not Touching Components	<input type="checkbox"/>	Bottom Elbow	<input type="checkbox"/>
Product Tank	<input type="checkbox"/>	Bottom O ring	<input type="checkbox"/>
Top	<input type="checkbox"/>		
Bottom	<input type="checkbox"/>		

TESTING COMMENTS:-

PACKING CHECKLIST

Miscellaneous: Power Cord Wires Connected Purge Loop Secure

Machine Labels: Serial No. Manual

Shipping Box Labels: Fragile This Side Up Box Model/Serial No. Sticker

Spare Parts List

PART NAME	PART NUMBER	QUANTITY
Strain Relief for Power Cord	1820018-001	1
Timer 115 VAC/230 VAC	1850001-002	1
Valve Wire Harness (each) 115 VAC	1880011-004	1
Valve Wire Harness (each) 230 VAC	1880011-005	1
Power Cord (with 3-Prong Plug)	1890001-001	1
Inline Check Valve	1530001-C01	2
1/4" Safety Relief Valve-55#	1540001-C01	1
Silencer	1700002-D01	1
Solenoid Valve 115 VAC	1510008-110	1
Solenoid Valve 230 VAC	1510008-220	1
Oxygen Receiver Tank	1140003-002	1
1/4" Green Oxygen Tubing - Per Foot	2210004-C01	3
1/2" Poly Tubing - Per Foot	2210004-E02	2
Purge Loop Assembly	7040001-001	1
Replacement Set of Sieve Beds	7060001-001	1
Manual – Available Free on Website	9000000-006	1

Oxygen Cleaning Procedure

Scope

This procedure sets forth the cleaning requirements for parts that are used in the construction of **OGSI** oxygen systems and are in the gaseous oxygen product stream, including but not limited to valves, tubing, fittings, manifolds and pipes. This procedure represents the method for cleaning OGSI oxygen service equipment. These cleaning methods and subsequent inspections result in a degree of cleanliness required for the safe operation of the oxygen service equipment.

This document is based on guidelines provided in the Compressed Gas Association (CGA) publication **CGA G-4.1-2009**, and is intended to comply with that publication.

Supersession

This procedure supersedes all previous written and verbal direction set forth with Audubon Machinery Corp and its operating subsidiaries on the topic of cleaning and preparing parts for oxygen service.

The Chief Engineer, or his/her delegate, shall periodically review this document as well as other industry relevant procedures and publications to ensure consistency between AMC internal procedure and industry norms.

Safety

Contamination such as grease, dirt, oil, dust, solvents, weld slag, sand, rust, paper, fiber, rags, wood, coal, and previously applied thread sealants on parts that come into contact with oxygen can cause a combustion reaction resulting in system degradation, failure, or a hazard to nearby personnel. Care needs to be taken in the cleaning and handling of components used in oxygen service to prevent any contamination related failure.

While the **CGA G-4.1-2009** standard makes allowance for cleaning parts using caustic agents, acids or solvents, the **OGSI** procedure will use only mechanical (soaking, wire brushing or grinding) means for pre-cleaning and hot water cleaning with aqueous detergents for final cleaning. An effective rinse with potable water is mandatory and applied to ensure that the residual cleaning agent is removed from the system.

Training

Personnel involved in the cleaning, preparation, and assembly of parts used in oxygen service will be trained in these cleaning procedures and be familiar with this document. Documented evidence of training (with annual refresher training) shall be maintained by the supervisor of each impacted employee.

Process Flow Chart

The flow chart below describes oxygen cleaning and parts handling process.

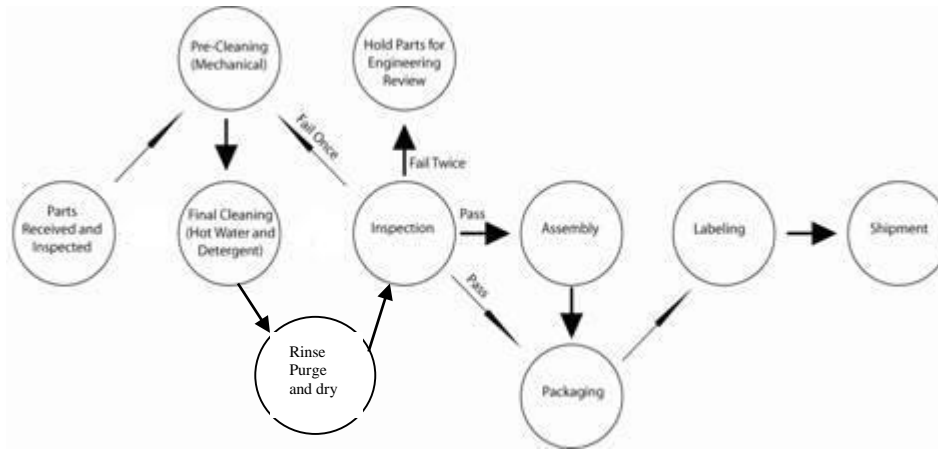

Parts Received and Initial Inspection

Upon determining which parts need to be cleaned, the technician needs to perform an initial visual inspection (under white light). Check for the presence of visible residue on the parts including but not limited to oil, grease, dirt, dust, rust, weld slag or pre-existing thread sealant among others. For parts that have an internal cavity that is not directly observable by the naked eye, a lint free cloth that is first soaked in water can be inserted into the part and withdrawn for evidence of contamination. No part failing inspection shall be used in any assembly.

Pre-Cleaning

Pre-cleaning methods include soaking parts in a water based solution with an aqueous detergent, using a wire brush or thread pick, holding it under a wire brush grinding wheel or simply wiping it down with a clean rag. Upon completion of pre-cleaning, the part should be clear of any visible contamination and ready for final cleaning.

Final Cleaning

Final cleaning involves placing the parts into either (1) the parts washing machine, adding an appropriate amount of detergent and running them through the cleaning cycle, or (2) placing the parts into the aqueous ultrasonic cleaning machine, selecting the designated temperature and cycle time, or (3) performing a 15 minute flush of aqueous detergent solution through a hose or cavity, and then rinsing the part(s) in a potable water rinse once complete. Consideration shall be given to the size, shape and number of parts to be cleaned at one time to ensure that the system is not overloaded or its function impaired. The cleaning temperature inside the washers shall be **120°F (49°C)** to **140°F (60°C)** and the detergent to be used shall be Cascade™. Parts can be removed from the washer once the drying cycle is complete.

Inspection

Upon completion of the final rinse cycle, all parts should be removed from the parts washing machine and visually inspected with both a bright white light and an ultraviolet (“black”) light for any residual contamination. The item shall be observed to confirm the absence of any contaminants including any oil, grease, detergent, moisture, lint, or other foreign materials. If any material remains on the part after the final cleaning cycle, the part shall be returned for a second round of pre-cleaning, final cleaning, and rinse.

If a part is processed through this cycle twice and continues to exhibit signs of contamination, the part shall be noted as non-conforming and processed per the company Control of Non-Conforming Material (QP-03).

Assembly, Handling, and Packaging

Once a part or assembly has been cleaned for oxygen service, it should be either immediately assembled into the final assembly, or protected to prevent recontamination if it will be put into storage.

Personnel handling O2 cleaned parts shall wear powder free Nitrile examination gloves. When practical, internal cavities of assemblies and machines in process shall be capped, closed or otherwise protected to prevent the introduction of contamination during the assembly process.

If immediate use is not intended or is impractical, the O2 cleaned part will be packed in a manner to prevent recontamination. Small to medium sized parts will be packaged in sealed plastic bags. Larger assemblies will be bubble-wrapped or wrapped in foam material, openings protected with caps and/or plugs, and then moved to final packaging in boxes and/or crates.

When servicing O2 parts outside of the factory, field technicians must take care to handle parts with nitrile gloves, and to thoroughly flush and degrease the parts prior to use. Whenever practical, the parts should be cleaned and packaged following this process prior to departure from the factory. A mechanical brush cleaning, followed by a flush with copious amounts of isopropyl alcohol may be substituted for simple parts with no hidden cavities. A visual inspection using a bright white and ultraviolet (“black”) must be performed. Removal/purging of any residual IPA can be considered complete when the solvent cannot be detected by appropriate methods

Labeling

Once a part or an assembly has been cleaned and packaged for oxygen service, it should be labeled per the customer’s instructions, but at a minimum;

- contain the statement “**Cleaned for Oxygen Service per EP002 Do Not Open Until Ready to Use**”
- Part Number
- Date of cleaning or packaging
- Date of Inspection with inspector’s mark

References

The following publications were referenced in the creation of this document.

- CGA G-4.1-2009, *Cleaning Equipment for Oxygen Service*, Compressed Gas Association, Inc., 4221 Walney Road, 5th Floor, Chantilly, VA 20151. www.cganet.com
- *Oxygen Cleaning Procedure* Rev. L (8/05), RIX Industries, Inc., 4900 Industrial Way, Benicia, CA 94510. www.rixindustries.com
- ASTM MNL36-2, *Safe Use of Oxygen and Oxygen Systems: Handbook or Design, Operation, and Maintenance*, ASTM International, West Conshohocken, PA ©2007

Units of Measurement

lb	U.S. Pound
hp	Horsepower
psi	Pound-force per Square Inch
kW	Kilowatt
ft³	Cubic Feet
VAC	Volts Alternating Current
Hz	Hertz
SCFH	Standard Cubic Foot per Hour
SCFM	Standard Cubic Foot per Minute
LPM	Liter Per Minute
1 bar	1.45 x 10 ¹ psi
dBA	Decibel (A scale)
A	Ampere
W	Watt
°C	Degree Celsius/Centigrade
°F	Degree Fahrenheit

