



CHILLER MODELS: CH5000

Operator's & Installation Manual



Release Date: July 01, 1997

Publication Number: 91961

Revision Date: April 25, 2014

Revision: J

Visit the Cornelius web site at www.cornelius.com for all your Literature needs.

The products, technical information, and instructions contained in this manual are subject to change without notice. These instructions are not intended to cover all details or variations of the equipment, nor to provide for every possible contingency in the installation, operation or maintenance of this equipment. This manual assumes that the person(s) working on the equipment have been trained and are skilled in working with electrical, plumbing, pneumatic, and mechanical equipment. It is assumed that appropriate safety precautions are taken and that all local safety and construction requirements are being met, in addition to the information contained in this manual.

This Product is warranted only as provided in Cornelius' Commercial Warranty applicable to this Product and is subject to all of the restrictions and limitations contained in the Commercial Warranty.

Cornelius will not be responsible for any repair, replacement or other service required by or loss or damage resulting from any of the following occurrences, including but not limited to, (1) other than normal and proper use and normal service conditions with respect to the Product, (2) improper voltage, (3) inadequate wiring, (4) abuse, (5) accident, (6) alteration, (7) misuse, (8) neglect, (9) unauthorized repair or the failure to utilize suitably qualified and trained persons to perform service and/or repair of the Product, (10) improper cleaning, (11) failure to follow installation, operating, cleaning or maintenance instructions, (12) use of "non-authorized" parts (i.e., parts that are not 100% compatible with the Product) which use voids the entire warranty, (13) Product parts in contact with water or the product dispensed which are adversely impacted by changes in liquid scale or chemical composition.

Contact Information:

To inquire about current revisions of this and other documentation or for assistance with any Cornelius product contact:

www.cornelius.com

800-238-3600

Trademarks and Copyrights:

This document contains proprietary information and it may not be reproduced in any way without permission from Cornelius.

This document contains the original instructions for the unit described.

CORNELIUS INC
101 Regency Drive
Glendale Heights, IL
Tel: + 1 800-238-3600

Printed in U.S.A.

TABLE OF CONTENTS

Safety Instructions	1
Read and Follow ALL Safety Instructions	1
Safety Overview	1
Recognition	1
Different Types of Alerts	1
Safety Tips	1
Qualified Service Personnel	1
Safety Precautions	2
Shipping And Storage	2
General Information	3
Introduction	3
Specification Notes	3
Installation	4
Location	4
Electrical	5
Plumbing	5
Chiller with Reservoir	5
Chiller without Reservoir	5
Start Up	7
Water Flow Start-Up	7
Chiller with Pump	7
Chiller without Pump	7
Standard Therostat Eliwell IC902	7
Dual Point Adjustment (Optional)	8
Cooling Start-Up	8
Control Panel	8
Maintenance	9
Fluid Recommendation	10
Safety Controls	11
High Pressure Control (HPC)	11
Low Temperature Control (LTC)	11
Low Pressure Control (LPC)	11
Service	13
Troubleshooting	14
Parts List	15
Chiller Assembly	15
Pump and Tank Components	16
Electrical Box Components	17
Wiring Diagram	18



SAFETY INSTRUCTIONS

READ AND FOLLOW ALL SAFETY INSTRUCTIONS

Safety Overview

- Read and follow **ALL SAFETY INSTRUCTIONS** in this manual and any warning/caution labels on the unit (decals, labels or laminated cards).
- Read and understand ALL applicable OSHA (Occupational Safety and Health Administration) safety regulations before operating this unit.

Recognition

Recognize Safety Alerts



This is the safety alert symbol. When you see it in this manual or on the unit, be alert to the potential of personal injury or damage to the unit.

DIFFERENT TYPES OF ALERTS

DANGER:

Indicates an immediate hazardous situation which if not avoided **WILL** result in serious injury, death or equipment damage.

WARNING:

Indicates a potentially hazardous situation which, if not avoided, **COULD** result in serious injury, death, or equipment damage.

CAUTION:

Indicates a potentially hazardous situation which, if not avoided, **MAY** result in minor or moderate injury or equipment damage.

SAFETY TIPS

- Carefully read and follow all safety messages in this manual and safety signs on the unit.
- Keep safety signs in good condition and replace missing or damaged items.
- Learn how to operate the unit and how to use the controls properly.
- **Do not** let anyone operate the unit without proper training. This appliance is **not** intended for use by very young children or infirm persons without supervision. Young children should be supervised to ensure that they do not play with the appliance.
- Keep your unit in proper working condition and do not allow unauthorized modifications to the unit.

QUALIFIED SERVICE PERSONNEL

WARNING:

Only trained and certified electrical, plumbing and refrigeration technicians should service this unit. **ALL WIRING AND PLUMBING MUST CONFORM TO NATIONAL AND LOCAL CODES. FAILURE TO COMPLY COULD RESULT IN SERIOUS INJURY, DEATH OR EQUIPMENT DAMAGE.**

SAFETY PRECAUTIONS

This unit has been specifically designed to provide protection against personal injury. To ensure continued protection observe the following:

 **WARNING:**

Disconnect power to the unit before servicing following all lock out/tag out procedures established by the user. Verify all of the power is off to the unit before any work is performed.

Failure to disconnect the power could result in serious injury, death or equipment damage.

 **CAUTION:**

Always be sure to keep area around the unit clean and free of clutter. Failure to keep this area clean may result in injury or equipment damage.

SHIPPING AND STORAGE

 **CAUTION:**

Before shipping, storing, or relocating the unit, the unit must be sanitized and all sanitizing solution must be drained from the system. A freezing ambient environment will cause residual sanitizing solution or water remaining inside the unit to freeze resulting in damage to internal components.

GENERAL INFORMATION

INTRODUCTION

Remcor "CH" Series Refrigerated Recirculating Water Chillers are designed to provide a continuous flow of clean cooling water at a constant temperature and to handle a variety of closed loop and tank cooling applications.

The CH consists of a refrigeration system with associated operating controls housed in a sturdy sheet metal cabinet. A standard pump and reservoir package provides a complete self-contained water cooling and circulating system.

CH Chillers are designed to operate in a clean laboratory or industrial environment where ambient temperatures range from 50° F to 100° F. Once properly installed, the CH Chiller will run virtually maintenance free and provide a constant supply of cooling liquid to the application.

NOTE: Please read through this manual before starting the chiller.

Table 1. Specifications

Model	CH5000
Cooling Capacity* Watts/BTU	17,584/60,000
Compressor	5 H.P.
Condenser	Air Cooled
Temperature Controller	Digital Display 40-100° F
Pump*	2CS (12 GPM @ 50 PSI)
Reservoir	40 Gallons
Voltage (Full Load Amps)	CH5002A 230/60/3 (28)
	CH5003A 460/60/3 (14)
Dimensions W x D x H (inches)	36" x 36" x 65"
Inlet/Outlet Fitting Size	1 inch

* Call the Service Department for proper pump identification.

SPECIFICATION NOTES

1. The figures for power and cooling capacity are listed for air-cooled units with a circulation temperature of 68° F, and ambient temperature of 80° F and standard pump.
2. Cooling capacity will be affected as follows: Derate 17% for 50 Hz operation. Derate 1% for each degree Fahrenheit drop in recirculating temperature. Derate 0.5% for each degree Fahrenheit increase in ambient temperature. Optional pumps will decrease net cooling capacity.
3. The operating water temperature range for water is 40° F to 100° F. If use of other fluids or temperatures are required, the Technical Service Department must be contacted so the appropriate ranges can be set.
4. All CH Chillers are thoroughly tested before leaving the factory to ensure that each unit meets these specifications prior to shipment.



WARNING:

Never operate the chiller with the panels removed. Always use the power switch to turn off the chiller when it is not being used. Always ensure that all air inlets and outlets are free of obstructions.

INSTALLATION

LOCATION

Install the chiller indoors in a well ventilated area where ambient temperatures will never fall below 50° F or rise above 100° F. To obtain optimum cooling capacity, the ambient temperature should be 80° F or below.

Standard CH Chillers have air-cooled condensers. On air-cooled units it is important that the air intake and discharge are not obstructed. Avoid hot air discharge from other equipment or enclosed areas where heat buildup could cause a significant rise in ambient temperatures. A minimum of two feet of space on all four sides of the chiller will be sufficient to prevent obstruction. Water-cooled units should be located near a water source and drain.

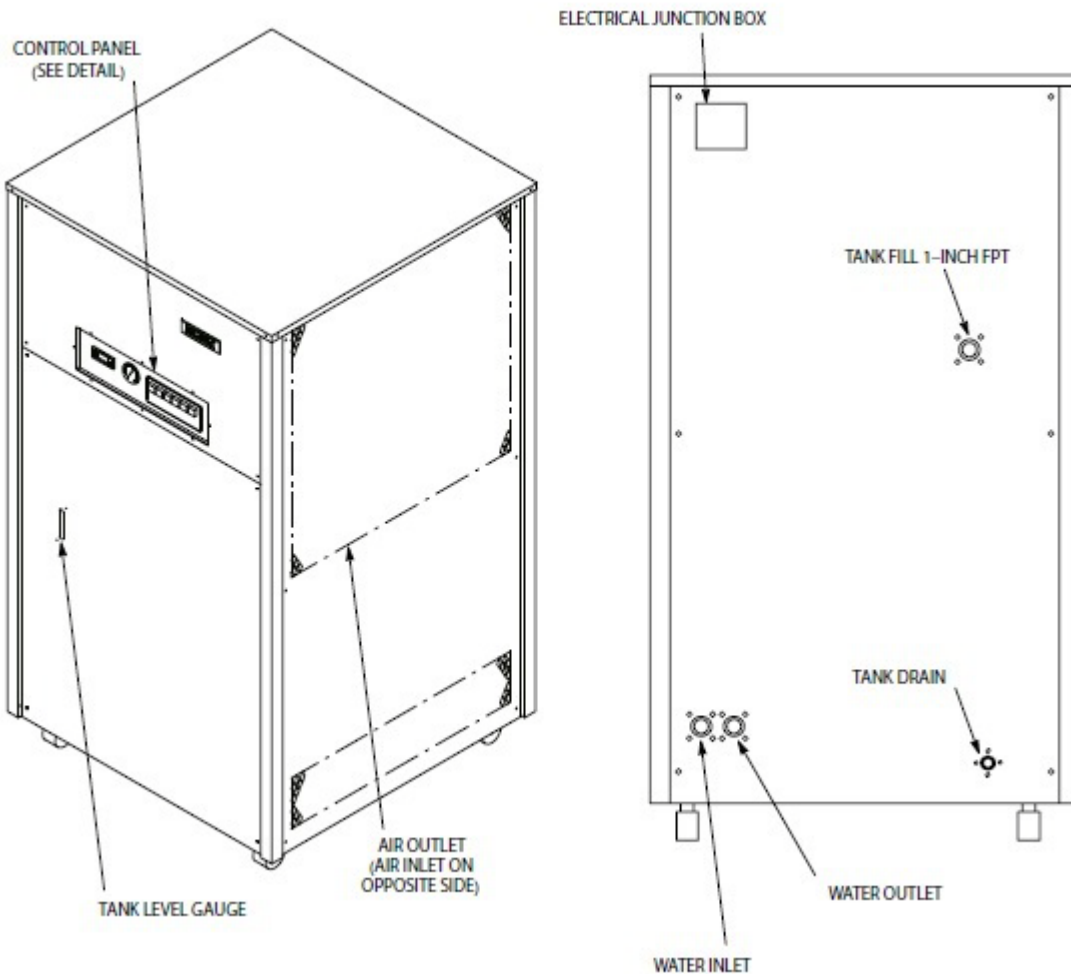

Figure 1. Installation Details

ELECTRICAL

All wiring must conform to the National Electric Code and any applicable local codes. The chiller must be PERMANENTLY wired by means of electrical conduit to a properly fused disconnect of proper amperage or wired to a properly rated power cord and plugged into an outlet with the appropriate disconnect and amperage rating. The electrical junction box located on the upper rear of the chiller, includes a four-terminal strip for power supply connections. The data plate, located beside the junction box, indicates the actual phase, voltage and amperage for each chiller.



CAUTION:

On three phase applications, it is important that the rotation of the pump, when supplied, is correct. Running the pump in reverse for more than a few seconds results in permanent pump damage. When the pump is running, shaft rotation must match the direction indicated on the pump housing. If the rotation is incorrect, reverse two of the three incoming power supply leads.

PLUMBING

Follow standard plumbing practices and local codes in making water connections. The chiller inlet and outlet connections are 1-inch FPT. Flexible hose and fittings are recommended for plumbing the system. A No. 20 mesh strainer should be installed on the chiller inlet to prevent foreign particles from entering the system and should be cleaned monthly. Lines should be routed with as few bends as possible. Prevent lines from running near radiators, hot water pipes, etc. Any lengths of tubing that are exposed to high ambient temperatures should be insulated to prevent condensation and/or significant liquid heat loss.

Chiller with Reservoir

The reservoir can be filled by removing the water fill cap located on the upper rear of the chiller (See Fluid Recommendations section). After ensuring that the drain valve is closed, fill the reservoir via the full port with clean water until the water level sight glass on the front of the unit indicates "FULL" the fill cap should then be reinstalled before operation begins.

Chiller without Reservoir

The chiller and system piping should be filled with clean water ensuring that all air is purged from the system.

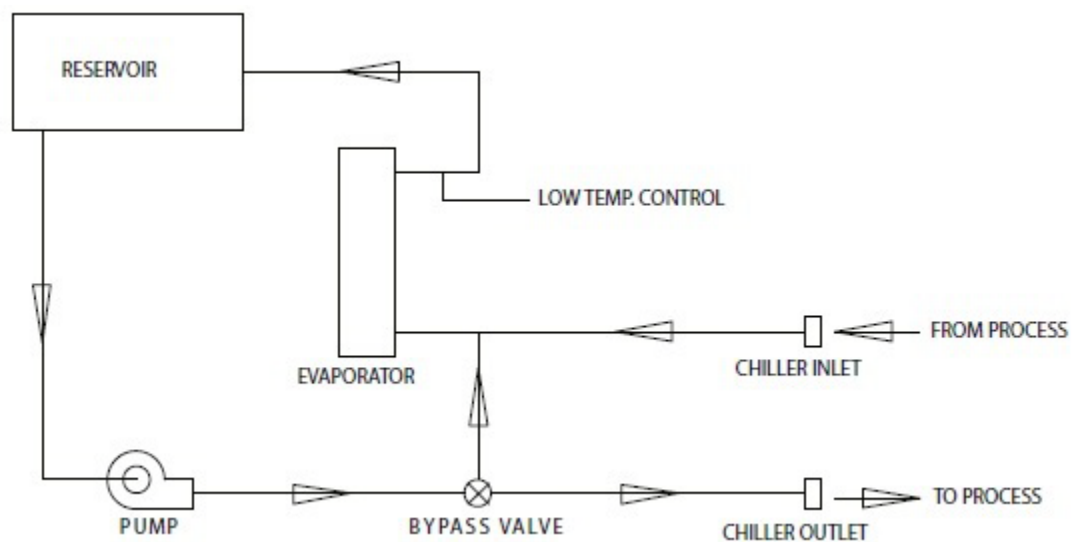

Figure 2. Chiller Plumbing Schematic with Pump and Tank (Standard)

START UP

WATER FLOW START-UP

Chiller with Pump

It is important to check the pump rotation on the three phase units. Remove the lower side panel to expose the pump. Turn the pump power switch to the "ON" position for a few seconds. Observe the motor shaft to ensure that it is turning in the direction indicated by the arrow located on the pump housing. If the rotation is incorrect, reverse two of the three incoming power supply leads at the terminal strip. After changing the leads, check the pump rotation.

WARNING:

Running the pump in reverse for more than a few seconds results in permanent pump damage.

After ensuring that the system piping is free from obstruction and that all valves are open, turn the pump power switch to the "ON" position. The pump power indicator should illuminate, indicating that the pump is operating.

All Chillers with pumps are provided with a pressure regulating valve on the pump discharge. This valve is preset at the factory to ensure that system pressure does not exceed the capabilities of the pump motor and/or piping. If this valve requires adjustment, please contact the factory for proper setting procedure and pressures.

A flow meter and throttling valve can be added in the chiller inlet line in order to monitor and/or adjust the flow rate through the Chiller.

Once the flow has been established, the thermostat can be adjusted to the desired set-point.

Chiller without Pump

A flow meter and throttling valve can be added in the Chiller inlet line in order to monitor and/or adjust the flow rate through the Chiller.

Once the flow has been established, the thermostat can be adjusted to the desired set-point. See thermostat adjustment.

STANDARD THEROSTAT ELIWELL IC902

The following procedure should be followed to adjust the Eliwell IC902 thermostat temperature setting:

1. To set the "SET POINT", press and release the "SET" button. "SET" displays.
2. Press the "SET" button again, the current "SET POINT" is displayed. Press the UP or DOWN button to change the "SET POINT" to the desired temperature.
3. Press the "FNC" button twice to exit the program. The current liquid temperature is displayed.

The thermostat has a range that is preset at the factory. The range is 40° F to 100° F. If operation outside of this range is required, please contact the Technical Service Department.

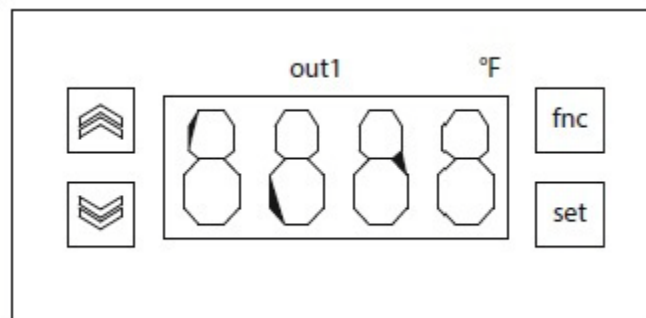

Figure 5. IC902 Eliwell Thermostat

Dual Point Adjustment (Optional)

1. To set the "SET POINT" for Level 1. Press and release the "SET" button, Re1 should be displayed.
2. Press the "SET" button, the current SET POINT TEMPERATURE should be displayed. Press the UP or DOWN button to change the SET POINT.
3. To set the "SET POINT" for Level 2. Press and release the "SET" button, Re2 should be displayed.
4. Press the "SET" button, the current SET POINT TEMPERATURE should be displayed. Press the UP or DOWN button to change the SET POINT.
5. Press the FNC button to exit the program.

The thermostat has a range that has been preset at the factory. The range is 40° F to 100° F. If operation outside of this range is required, please contact the Technical Service Department.

Cooling Start-Up

Once flow is established and the thermostat is set to the desired set-point, turn the control power switch to "ON". Ensure that the air is flowing in the left side (facing the control panel) and out the right side. If not, reverse two of the three incoming power supply leads at the terminal strip. Once again, check for correct air flow. All alarm indicators should be extinguished and the Chiller refrigeration system will cycle in order to maintain the established set-point.

Re-check the reservoir level to ensure that it is "FULL" (if so equipped) and add water if necessary.

The Chiller is now ready for normal operation.

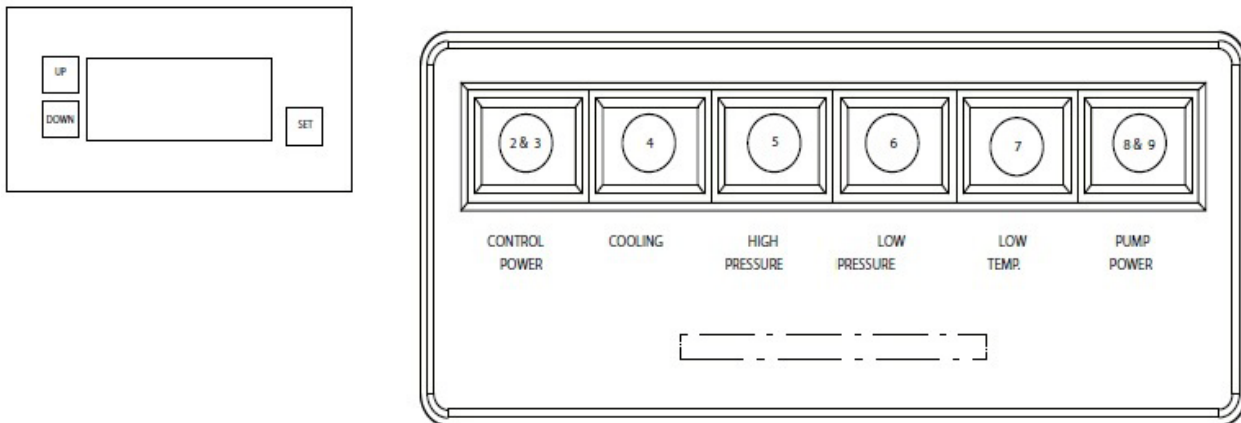

Figure 6. Control Panel

Control Panel

1. **TEMPERATURE INDICATOR/CONTROLLER (Thermostat)** – Combines a precise temperature control and accurate set ability with a convenient LED temperature readout that indicates system liquid temperature.
2. **CONTROL POWER SWITCH** – A simple (ON/OFF) switch that switches power to the control circuit. This switch must be "ON" for the Chiller to operate.
3. **COOLING LIGHT** – A green light that indicates refrigeration system operation. This light cycles on and off in response to the thermostat.
4. **HIGH PRESSURE ALARM LIGHT** – A red light that indicates high refrigeration pressure.
5. **LOW PRESSURE ALARM LIGHT** – A red light that indicates low refrigeration pressure.
6. **LOW TEMPERATURE ALARM LIGHT** – A red light that indicates and abnormally low system fluid temperature.
7. **PUMP POWER SWITCH** – A simple (ON/OFF) switch that switches power to the Chiller pump. This switch must be "ON" for the Chiller to operate.

MAINTENANCE



WARNING:

Disconnect power to the unit before servicing. Follow all lock out/tag out procedures established by the user. Verify all power is off to the unit before performing any work.

Failure to comply could result in serious injury, death or damage to the equipment.

The chiller requires very little normal maintenance.

1. On AIR-COOLED Chillers, the **condenser fins** should be cleaned by blowing compressed air through the condenser from the fan side as required to eliminate any dirt or debris that may accumulate over time. This can severely reduce the performance of the Chiller. Cleanable air filters are available as an option. Contact the factory for information.
2. The **circulation system** should be drained and flushed periodically to avoid build-up and possible restriction of flow by contaminants.

FLUID RECOMMENDATION

Chillers are designed to operate with water to provide maximum performance for temperatures of 40° F to 100° F.

Table 2.

Distilled Water	Acceptable
De-ionized Water (1-5 MEG/OHMS)	Acceptable
De-ionized Water (5+MEG/OHMS)	Acceptable with Stainless Steel & PVC only *No Copper or Brass
Propylene Glycol (Lab & Industrial Grade)	Acceptable - 30% Glycol/70% Water *For Applications with Temperatures below 40° F (4.4° C)
Lab & Industrial Grade Ethylene Glycol	Acceptable - 30% Glycol/70% Water *For Applications with Temperatures below 40° F (4.4° C)
Mineral/Hydraulic Oils (Viscosity<50 Centistrokes)	Acceptable
Ethylene Glycol (Commercial/Automotive Antifreeze)	NOT Acceptable *Silicate Rust Inhibitors in Automotive/Commercial Antifreeze damages pump seals and housing which leads to failure.
Acidic/Basic Solutions (Above 8/Below 6 PH)	Not Acceptable
Mineral/Hydraulic Oils (Viscosity>50 Centistrokes)	Not Acceptable

For questions regarding special or other fluids contact Cornelius at 800-238-3600.

To Purchase Lab or Industrial Glycol contact:

Cornelius - (800) 551-4423 - Part # 111521000, 5 gallons

Bevcor (866) 275-6392 - Part # 1008534, Chem Glycol Food Grade, 5 gallons

SAFETY CONTROLS

Each chiller is provided with three standard safety controls. These controls are arranged in series in the control circuit to automatically shut down the unit in the event that a condition exists which could be harmful to the refrigeration system components. This section includes a brief description of each control, its location and some troubleshooting hints that may be helpful.

HIGH PRESSURE CONTROL (HPC)

This control prevents system operation in the event that the high side pressure exceeds 250 PSIG. If this occurs, check the following:

1. That the condenser is clean and that the air inlets and outlets are unobstructed.
2. That the ambient temperature at the chiller location is below 100° F.
3. That the fan blade is rotating.

Press the reset button located on the front of the control to restart the chiller. This control is located in the upper left hand corner of the electric box. If the control opens again, check the control setting with refrigeration gauges. If the setting is correct, contact technical service department.

LOW TEMPERATURE CONTROL (LTC)

This control prevents system operation in the event that the fluid inside the evaporator falls below 35° F. If this occurs, check the following:

1. That the thermostat set point is set at 40° F or greater.
2. That the flow through the system is greater than 2 gallons per minute.

This control is mounted in the lower left hand corner of the electric box. It automatically resets itself once the water temperature is restored to 38° F. The low temperature control may be adjusted for lower temperatures if a glycol solution is used. Contact Technical Service Department for temperatures below those stated here (See Fluid Recommendations section).

LOW PRESSURE CONTROL (LPC)

This control prevents system operation in the event that the low side pressure falls below 44 psi. If this occurs, check the following:

1. That the thermostat set point is set at 40° F or greater.
2. That the flow through the system is greater than 2 gallons per minute.
3. That no bubbles are present in the sight glass.
4. That water bypass valve allows flow through the Chiller in a "dead head" situation.

This control is located to the right of the high pressure control in the electric box. It automatically resets itself once the low side pressure rises to approximately 64 psi. If the control opens again, check the control setting with refrigeration gauges. If setting is correct, contact Technical Service Department.

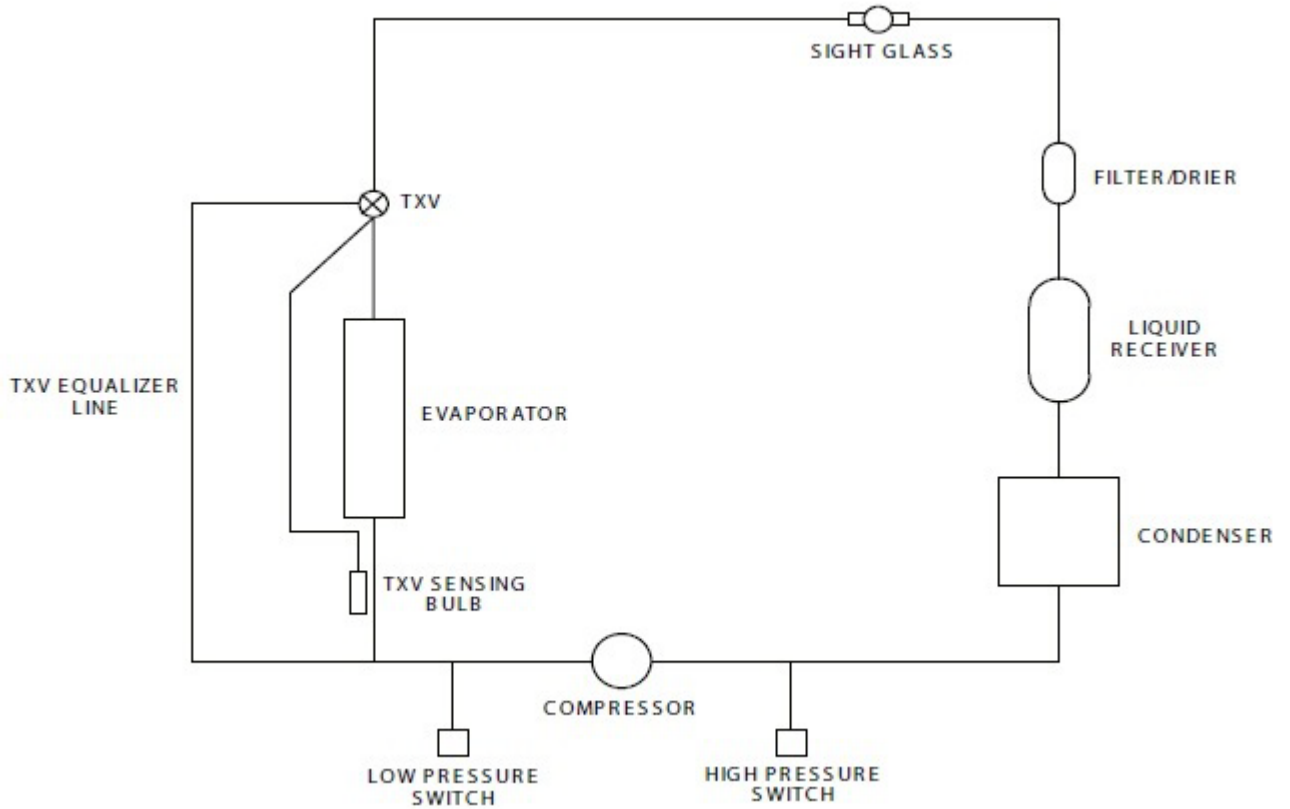

Figure 7. Refrigeration Piping Schematic without Hot Gas Bypass

SERVICE

When servicing a chiller, it is important to note the information contained on the data plate located in the upper rear of the unit.

If technical assistance is needed, the phone technician will need the Serial Number of your Chiller. That information is found on the Data Plate along with the model number, voltage requirements and refrigerant information.

The Serial Number is also needed when replacement parts are being ordered or for any warranty claims.

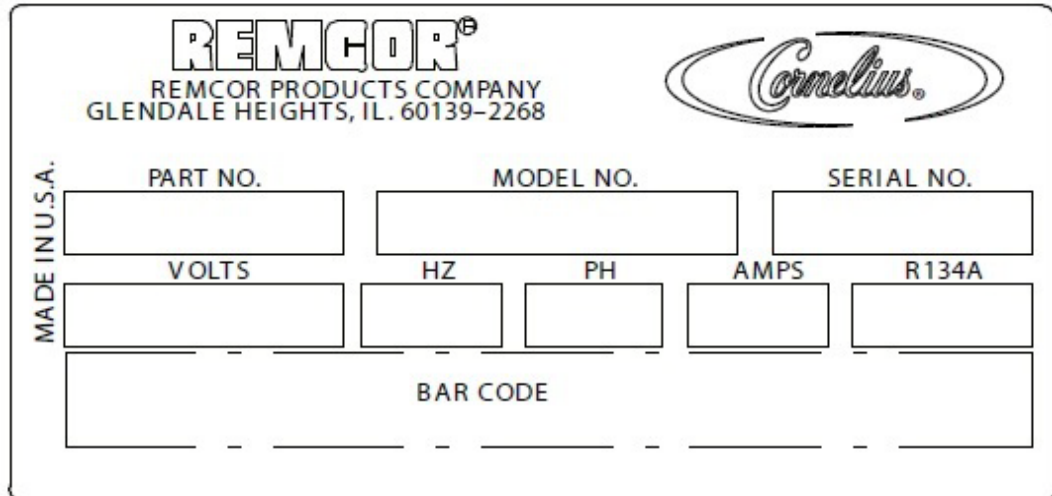

The data plate is a rectangular label with the following layout:

- Top left: **REMGOR[®]**
REMGOR PRODUCTS COMPANY
GLENDALE HEIGHTS, IL. 60139-2268
- Top right: 
- Left side (vertical text): **MADE IN U.S.A.**
- Row 1: Three boxes labeled **PART NO.**, **MODEL NO.**, and **SERIAL NO.**
- Row 2: Five boxes labeled **VOLTS**, **HZ**, **PH**, **AMPS**, and **R134A**
- Row 3: A large box labeled **BAR CODE**

Figure 8. Sample Data Plate for CH5002-A

Be sure to include the serial number on any documentation or billing information.

TROUBLESHOOTING

Table 3.

Trouble	Probable Cause	Remedy
Chiller does not operate. Control power light "off"	<ul style="list-style-type: none"> A. Control power switch "Off". B. No power. C. Defective power supply connection. D. Defective control power switch. E. Defective control transformer. 	<ul style="list-style-type: none"> A. Turn the control power switch to the "On" position. B. Check the fuse or circuit breaker. C. Check wiring and correct loose or poor connections. D. Replace the switch. E. Replace the transformer.
Pump does not operate. pump power light "off"	<ul style="list-style-type: none"> A. Pump power switch "Off". B. Defective pump power switch. C. Defective control transformer. 	<ul style="list-style-type: none"> A. Turn the pump power switch to the "On" position. B. Replace the switch. C. Replace the transformer.
Pump does not operate. Pump power light "On".	<ul style="list-style-type: none"> A. No water in reservoir. B. Restriction in the line to or from the chiller. C. Open or defective pump overload relay. D. Defective pump contactor. E. Defective pump motor or damaged impeller. 	<ul style="list-style-type: none"> A. Fill reservoir. B. Remove restriction. C. Manually reset the relay or replace if necessary and check amp setting on overload. D. Replace the pump contactor. E. Replace the pump or impeller.
Chiller does not cool. Cooling light "Off".	<ul style="list-style-type: none"> A. Defective thermostat. 	<ul style="list-style-type: none"> A. Replace thermostat.
Chiller does not operate. Cooling light "On". Low pressure alarm light cycles on/off.	<ul style="list-style-type: none"> A. Process water too cold. B. Low process water flow. C. Defective expansion valve. D. Refrigerant loss. E. Water bypass valve failed. F. Defective pump. 	<ul style="list-style-type: none"> A. Increase the thermostat setting. B. Ensure that there is adequate flow through the process piping. C. Replace the expansion valve. D. Check the sight glass. If bubbles are seen flowing through it, the chiller needs to be leak checked and recharged with refrigerant. E. Consult Technical Service Department. F. Replace pump.
High pressure alarm light "On".	<ul style="list-style-type: none"> A. Restricted condenser airflow. B. Defective condenser fan and/or motor. C. Defective expansion valve. D. Low or no condenser water flow. 	<ul style="list-style-type: none"> A. Clean the fins of the condenser and ensure that the air flow is not restricted. B. Check to ensure that the fan blade is not blocked. Replace the fan motor if necessary. C. Check to ensure that the fan blade is not blocked. Replace the fan motor if necessary. D. Ensure that there is adequate flow through piping to condenser.
Low temperature alarm	<ul style="list-style-type: none"> A. Low or no process liquid flow. B. Defective thermostat. C. Process water too cold – below 35° F. 	<ul style="list-style-type: none"> A. Ensure that there is adequate flow through the process piping. B. Replace the thermostat. C. Increase the thermostat setting.

PARTS LIST

CHILLER ASSEMBLY

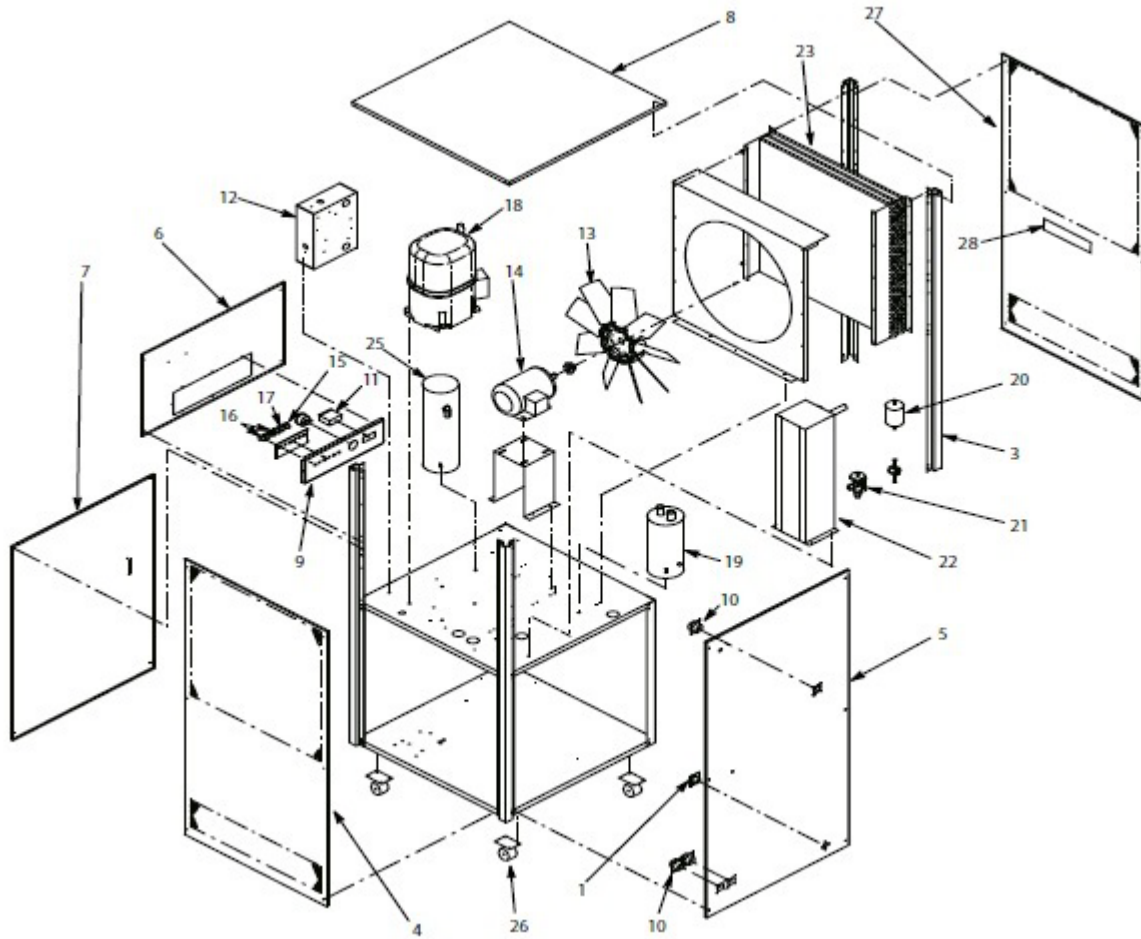

Figure 9.

Table 4. Chiller Assembly

SL No	Part No.	Description
1	22949	1/2" FPT Coupling
2	15404R	Thermowell, Low Temp. Thermostat (Not Shown)
3	15673	Corner Cover
4	15690	Side Panel
5	15691	Rear Panel
6	15685	Upper Front Panel
7	15686	Lower Front Panel
8	27576R	Lid
9	15687	Control Panel
10	27578R	FPT Coupling
11	32386	Temperature Control - Single Set Point
	33319	Temperature Control - Double Set Point
12	32753	Electric Box Assembly
13	32765	Fan Blade

Table 4. Chiller Assembly

SL No	Part No.	Description
14	32766	Fan Motor 230 Volt
		Fan Motor 460 Volt
15	620311601	White Switch/Indicator
16	620311605	Red Indicator
17	620311606	Green Indicator
18	620050991	Compressor 230 Volt
	620051068	Compressor 460 Volt
19	60907	Accumulator
20	61159	Filter/Drier
21	620050992	TXV Valve
22	620603903	Evaporator Assembly
23	60958	Condenser
25	60960	Receiver
26	71095	Caster
NS	620605902	Condenser, Water Cooled
NS	40199	Regulating Valve, Water Cooled Condenser

* Call the Technical Service Department for Proper Panel.

PUMP AND TANK COMPONENTS

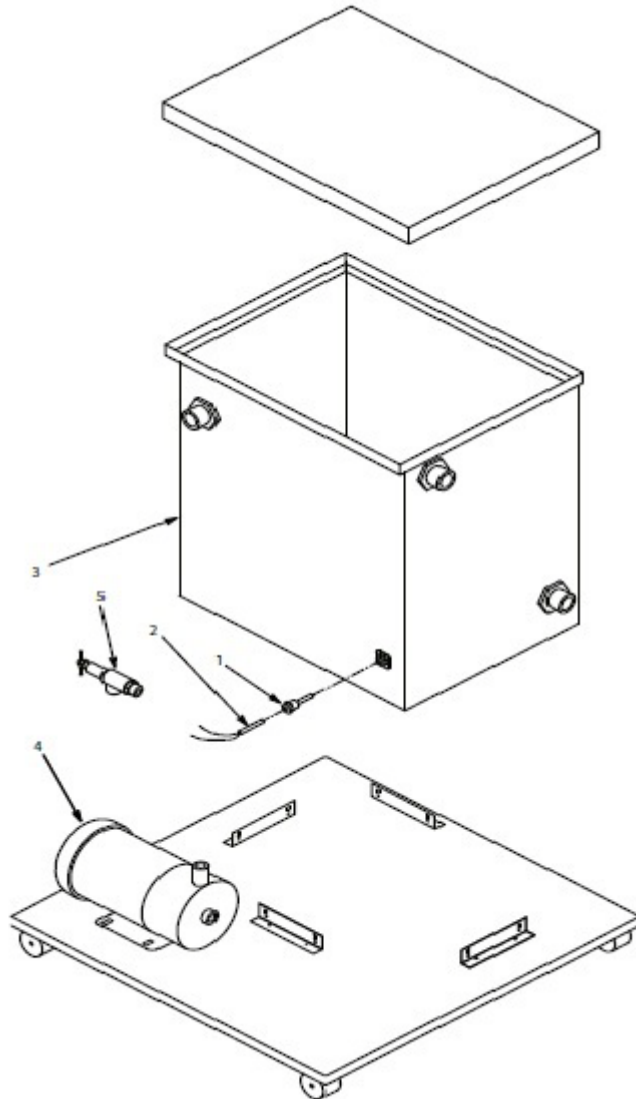

Figure 10. Pump and Tank Components

Table 5. Pump and Tank

SL No	Part No.	Description
1	15404R	Thermowell, Temperature Control
2	32589	Temperature Probe
3	52136	Tank Assembly
4	620710601	Pump Centrifugal 230 Volt
		Pump Centrifugal 460 Volt
5	40646	By-Pass Valve
* Call the Service Department for proper pump identification.		

ELECTRICAL BOX COMPONENTS

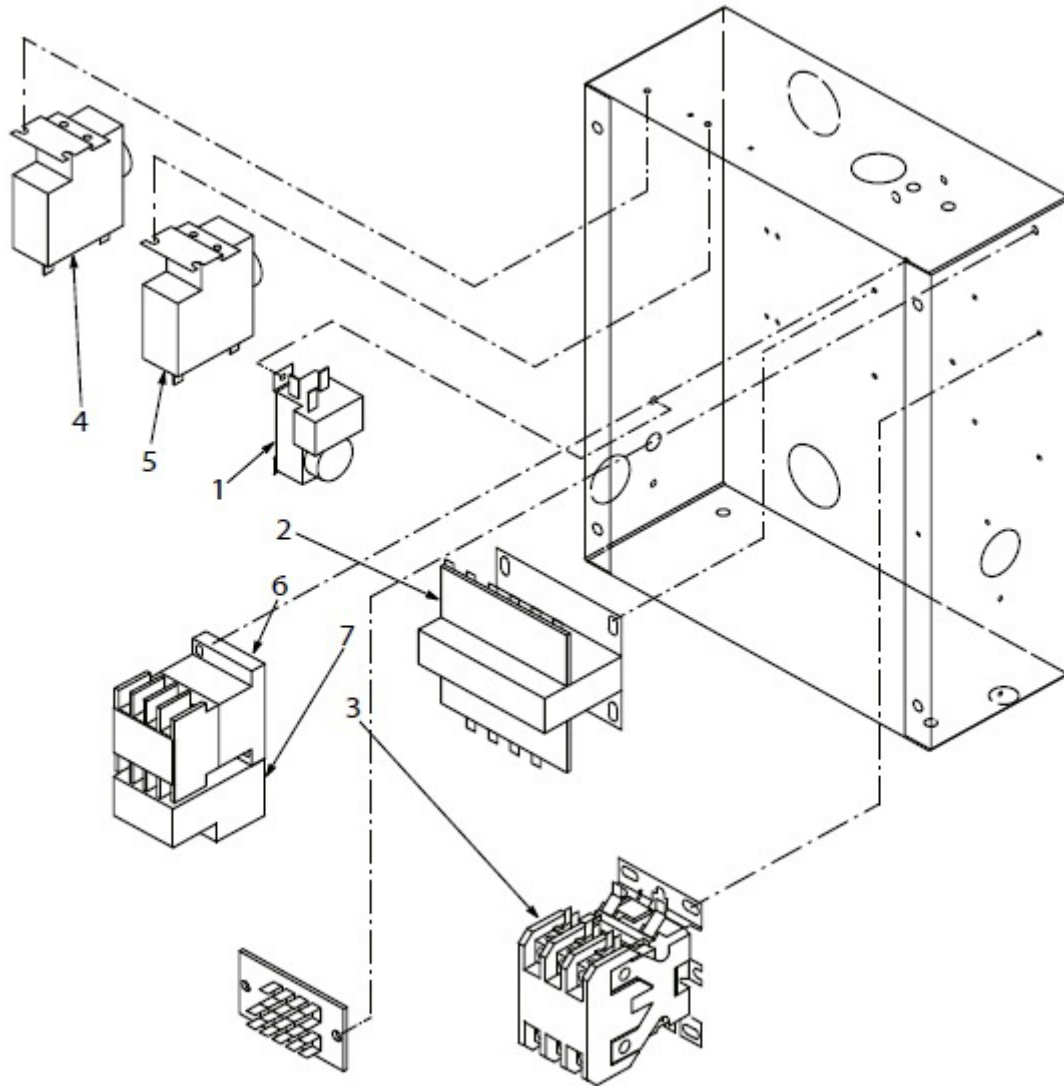

Figure 11. Electrical Box Components

Table 6. Electrical Box

SL No	Part No.	Description
1	31001	Low Temperature Thermostat
2	32804	Control Transformer
3	32805	Contactora, Compressor
4	60501	High pressure Control

Table 6. Electrical Box

SL No	Part No.	Description
5	60502	Low Pressure Control
6	620314008	Relay Contactora
7	620314005	Overload Relay, 2.20 to 3.10A
8	620314006	Overload Relay, 2.8 to 4.00A
9	620314007	Overload Relay, 4.50 to 6.50A

WIRING DIAGRAM

REMCOR "CH" SERIES CHILLERS
 WIRING DIAGRAM
 208-230V, 460V/3PH/50Hz, 60Hz
 WITH STANDARD PUMP CONTROL, W/ OPTIONAL HIGH TEMP. INTERLOCK,
 LOW FLOW INTERLOCK, AND LOW LEVEL AUDIBLE ALARM

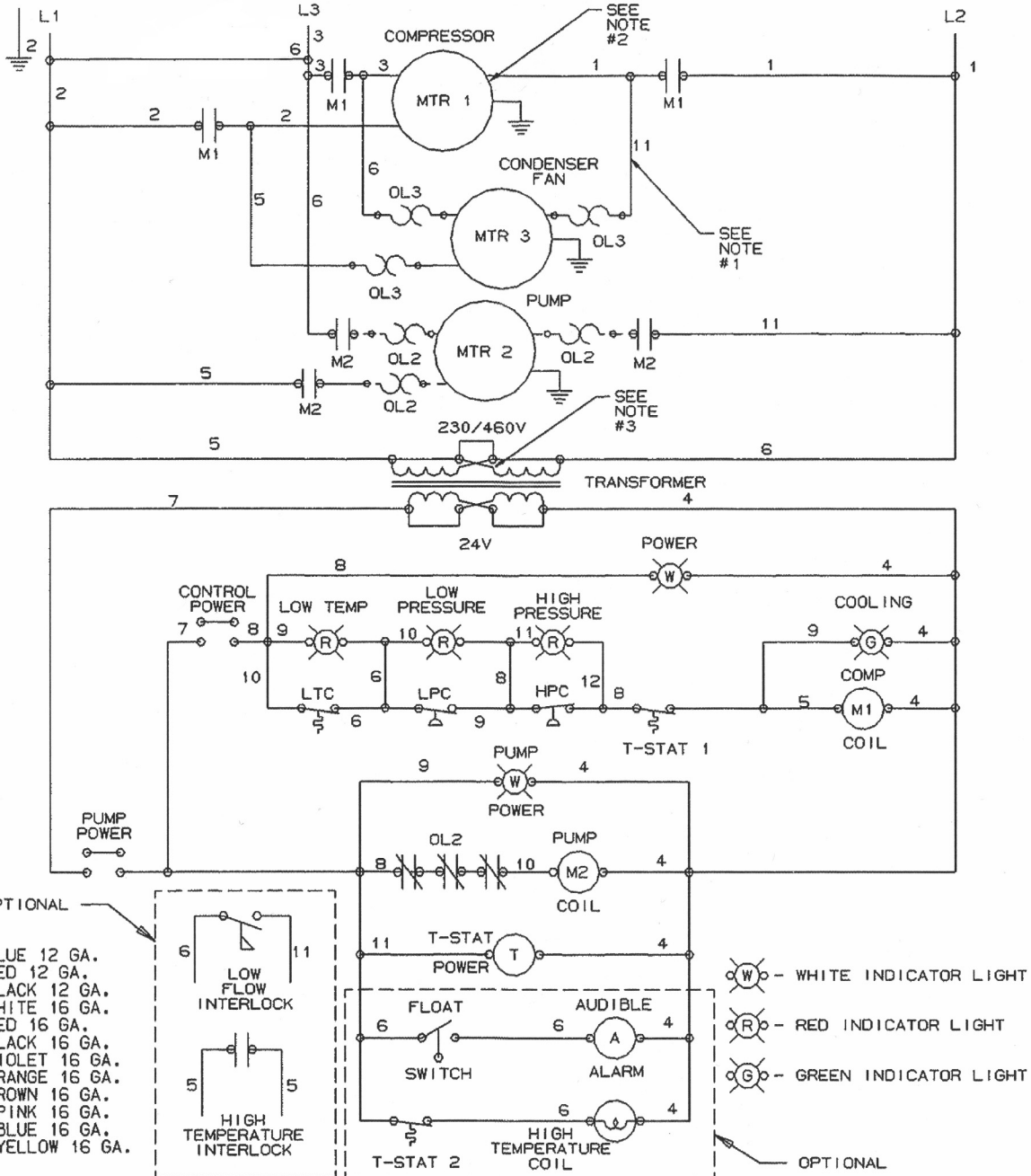

- 1-BLUE 12 GA.
- 2-RED 12 GA.
- 3-BLACK 12 GA.
- 4-WHITE 16 GA.
- 5-RED 16 GA.
- 6-BLACK 16 GA.
- 7-VIOLET 16 GA.
- 8-ORANGE 16 GA.
- 9-BROWN 16 GA.
- 10-PINK 16 GA.
- 11-BLUE 16 GA.
- 12-YELLOW 16 GA.

NOTES

1. CONDENSER FAN IS ONLY REQUIRED ON AIR COOLED UNITS.
2. THERMAL OVERLOADS ARE BUILT INTO THE COMPRESSORS.
3. SEE INSTRUCTION ON TRANSFORMER FOR HOOK UP.

92222 REVISION E

Figure 12. Wiring Diagram

Cornelius Inc.
www.cornelius.com