

ORT-15 Ozone Remediation Trailer

15 lb/day ozone trailer

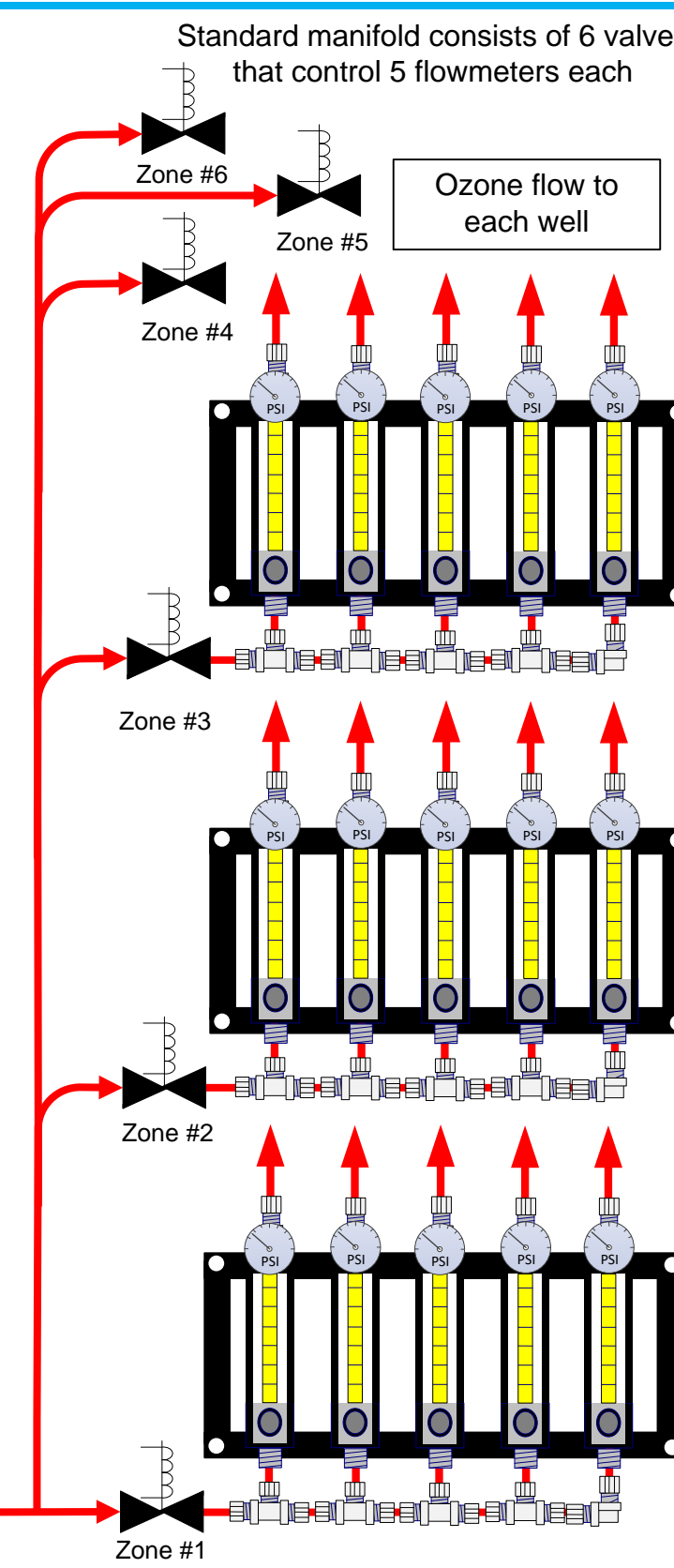
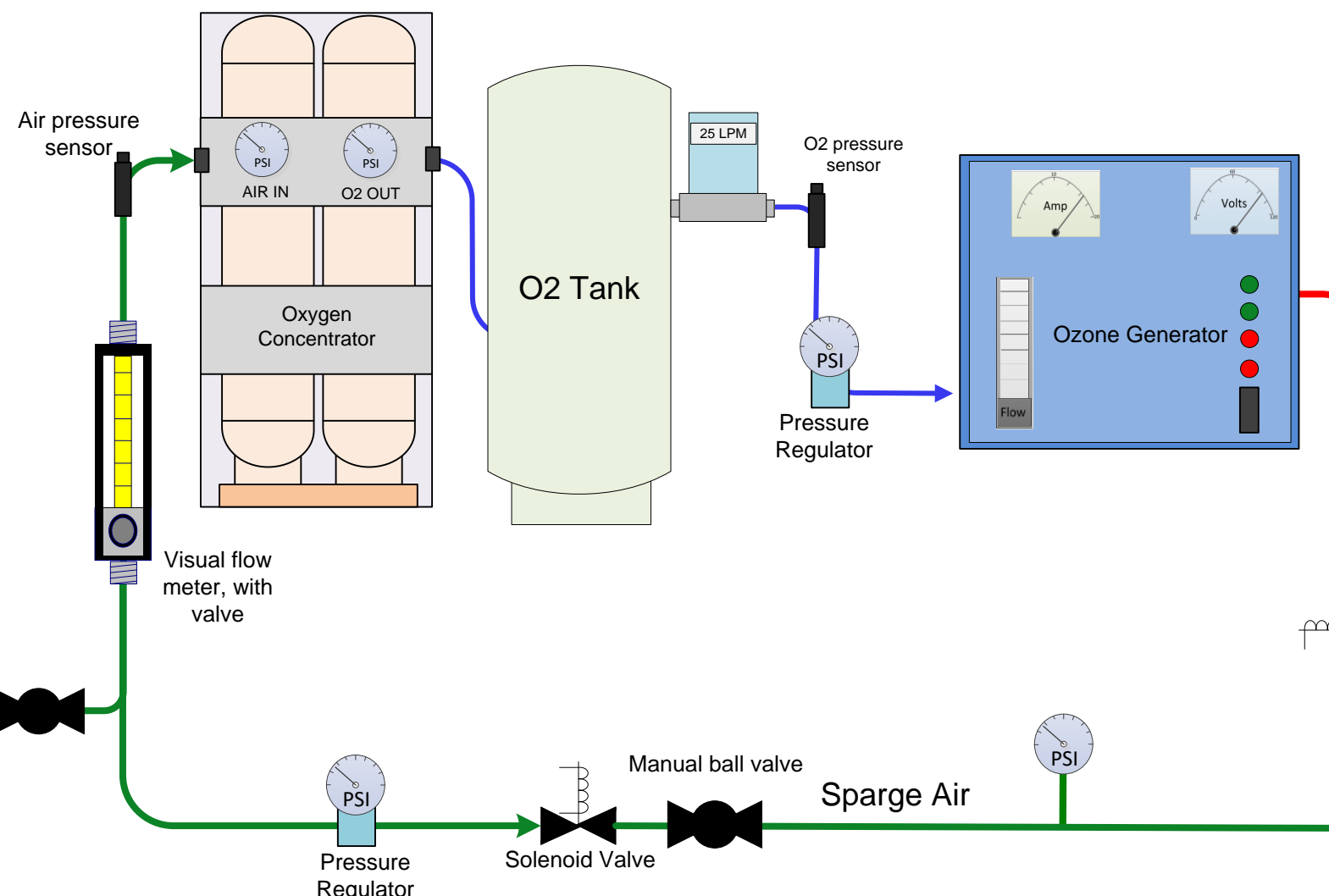
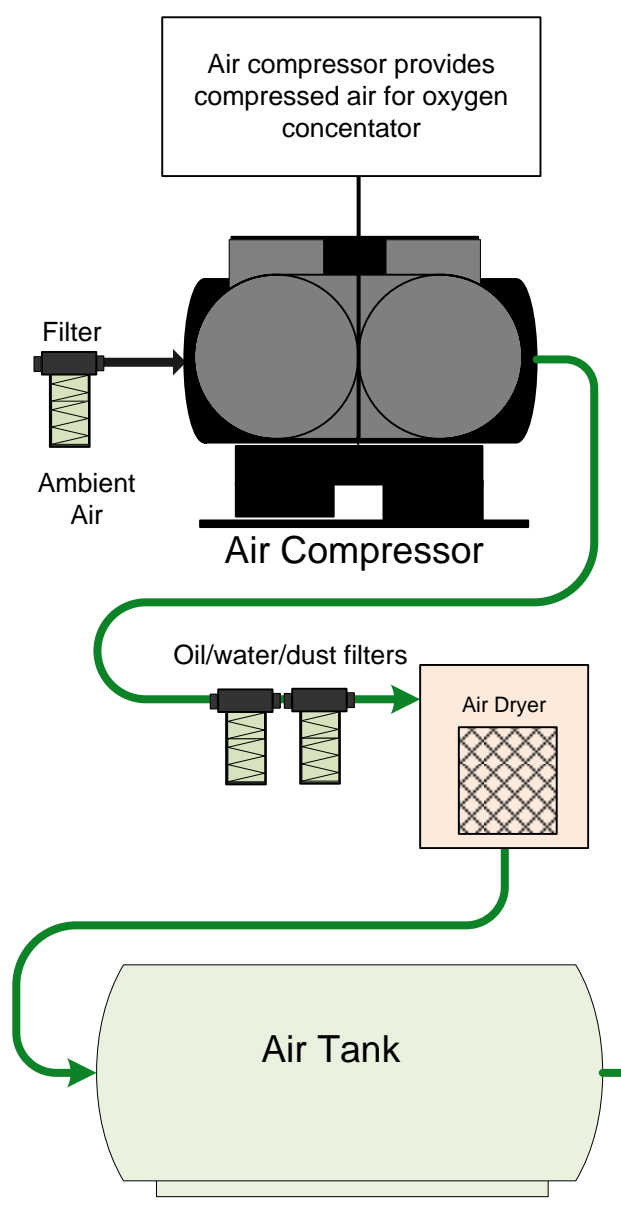
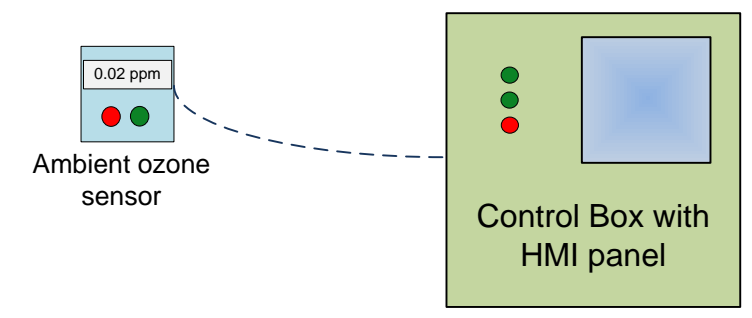
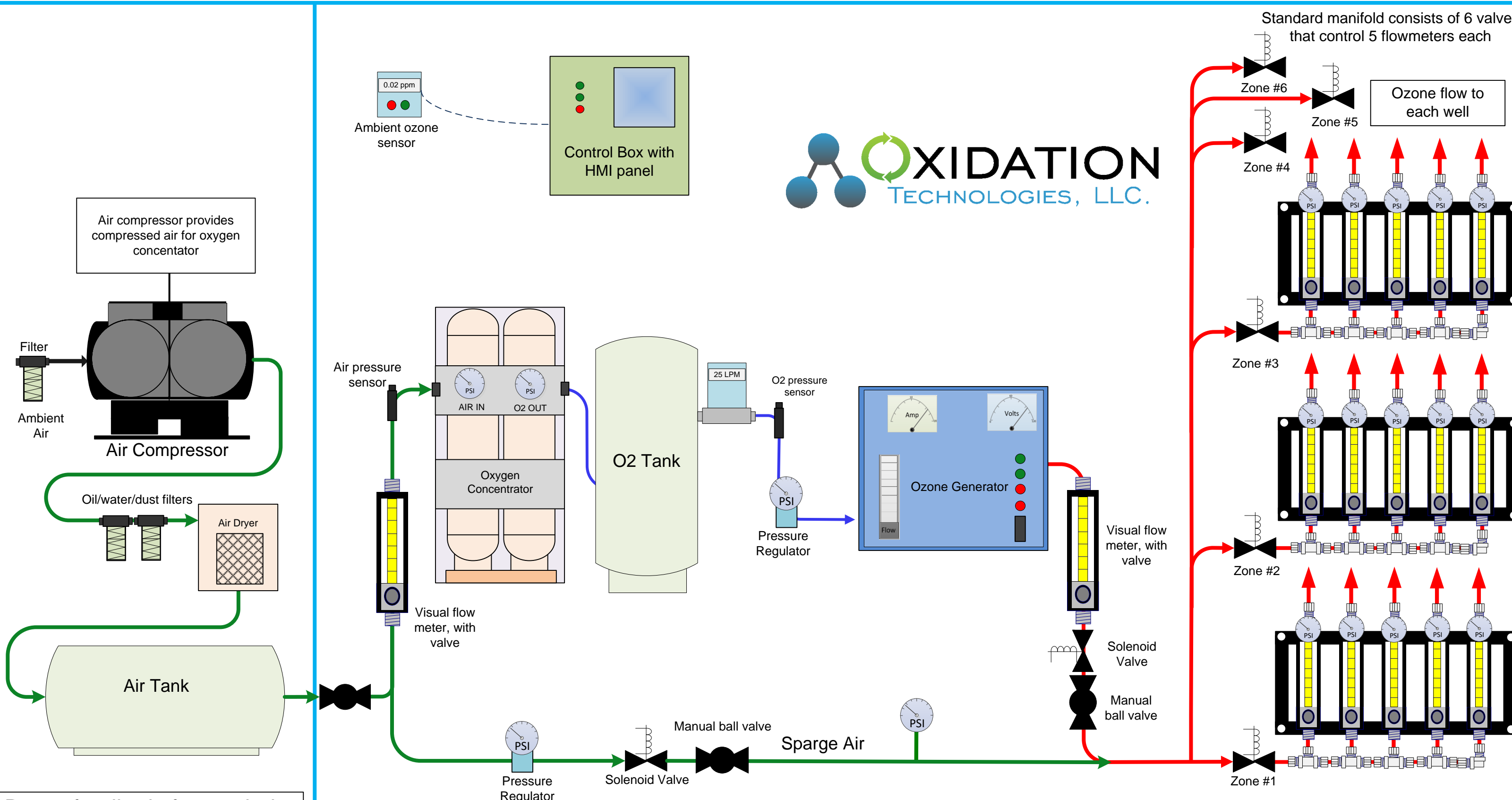

Rear of trailer is fan cooled – contains compressor, air dryer, and air filtration

Front of trailer is Air Conditioned and kept cool – contains O2 concentrator, O2 tank, O3 generators, manifold and control system.

Each Ozone output is regulated by a flowmeter to regulate flow to each valve, sets of flowmeters are configured in zones, each zone is controlled by PLC control system. *Manifold is representative, actual number of outputs may vary.*