

INSTALLATION NOTES FOR MAZZEI[®] INJECTORS

Factors which allow for reliable Mazzei[®] Injector operation are noted as follows:

- Mazzei Injectors require differential pressure to create suction. The injector's outlet pressure (backpressure) must be sufficiently lower than the inlet pressure. For most models, suction begins with a 25-30% pressure differential. To ensure consistent suction, the outlet side of the injector should be flooded or have some restriction downstream (backpressure).
- Mazzei Injectors should be installed with the main body in a horizontal position, or with the outlet facing up. The injector suction port can be oriented in any position.
- The injector should not be used as piping support, and plastic injectors should not be installed in steel pipe without flexible connections.
- Always use full flow isolation valves and non-restrictive fittings at least the same size as the inlet/outlet of the injector. Isolation valves and unions are recommended on the inlet and outlet for inspection and maintenance of the injector.
- The use of an appropriate thread sealant is recommended when attaching the inlet and outlet of the injector to the piping and fittings — *do not over-tighten*.
- Always hand tighten the suction port cap — never use tools to tighten the cap as this may damage the injector.
- Install pressure gauges near the inlet and outlet of the injector to monitor operating conditions.

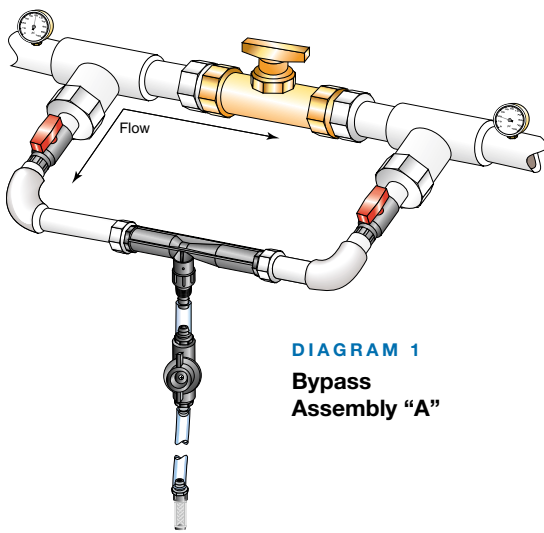
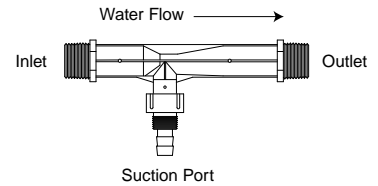

DIAGRAM 1
Bypass
Assembly "A"

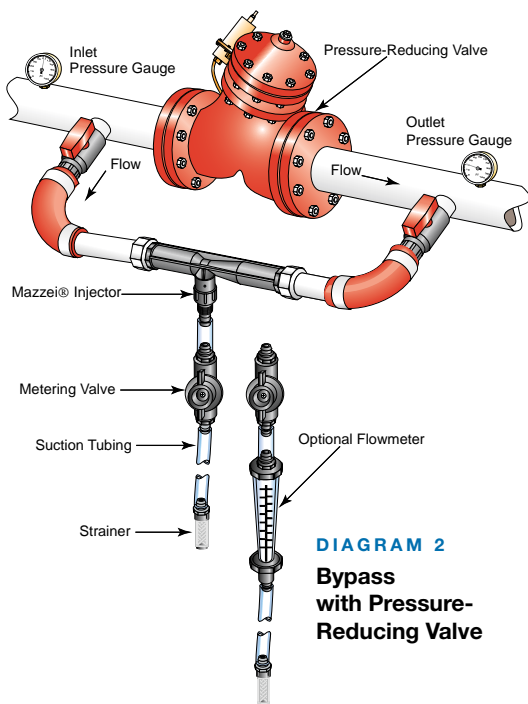

DIAGRAM 2
Bypass
with Pressure-
Reducing Valve

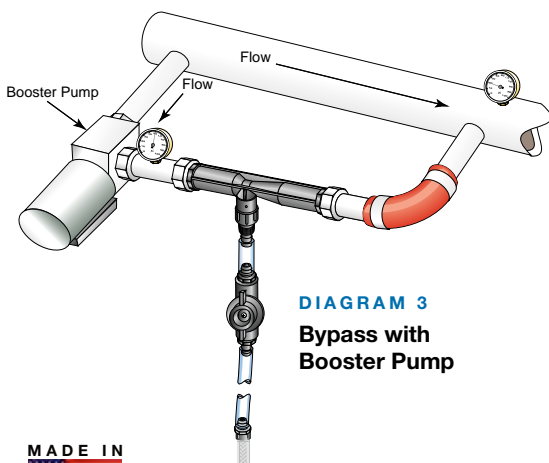

DIAGRAM 3
Bypass with
Booster Pump

Typical Installations

The injector is installed around a point of restriction, such as a regulator valve or a gate/ball valve. These create a differential pressure across the injector, thereby allowing the injector to produce a vacuum and draw in material. (DIAGRAMS 1+2)

When mainline pressure cannot be reduced, a small booster pump can be used to create a sufficient differential to operate the injector. (DIAGRAM 3)

Mazzei's standard configuration for injectors 1.5" or smaller includes a check valve integrated into the suction port. Inspect and test the check valve for proper operation prior to putting injector into operation. If the complete check valve is not present, other methods to prevent water from flowing backwards through the suction line should be considered. If you have any questions, please contact your distributor or Mazzei.

Install a proper backflow prevention device on the main water line to prevent potential chemical contamination of the source water supply. Always follow environmental regulations regarding backflow prevention and chemical use.

For additional information, including troubleshooting tips and injector performance data, please visit our website at www.mazzei.net.

© 2019 Mazzei Injector Company, LLC. MAZZEI[®], MIC[®], AIRJECTION[®], and TRU-BLEND[®] are registered trademarks of Mazzei Injector Corporation, as is the trade dress of the Mazzei injector under United States Registration No. 3170225. Mazzei products, and processes utilizing those products, are protected under various U.S. and non-U.S. patents and patents pending, including U.S. Patent Nos. 9,744,602; 9,744,502; 9,643,135; 9,643,134; 7,777,664; 7,040,839; 6,890,126; 6,866,703; 6,730,214; 6,193,893.