

REVISIONS			
REV.	DESCRIPTION	DATE	APPROVED
NC	RELEASED FOR SUBMITTAL.	6/5/2013	P. BANKOWSKI

NOTES:

- MATERIAL OF CONSTRUCTION: CD3MN, STAINLESS STEEL
- MTR/HEAT NUMBERS ARE PROVIDED AND SHALL MEET APPLICABLE MATERIAL SPECIFICATIONS.
- INLET/OUTLET CONNECTION:
3" DIA., SANITARY TRI-CLAMP FITTING
MATERIAL: CD3MN
SPECIFICATION: ASME BPE-2009
- SUCTION PORT CONNECTION:
2" DIA., SANITARY TRI-CLAMP FITTING
MATERIAL: CD3MN
SPECIFICATION: ASME BPE-2009
- WELDING JOINTS TO BE COMPLETE JOINT PENETRATION, WHERE POSSIBLE.
- DYE PENETRANT TESTING IN ACCORDANCE WITH ASME B31.3 NORMAL SERVICE RECOMMENDATIONS WILL BE PERFORMED ON A MINIMUM OF 20% OF LINEAR LENGTH OF WELDS; OR HYDROSTATIC TESTING WILL BE PERFORMED AS PART OF MAZZEI'S NON-DESTRUCTIVE TESTING PROCEDURE.
- CLEANED FOR PASSIVATION PER ASTM A380 GUIDELINES.
- PASSIVATED PER ASTM A967 SPECIFICATION.
- WELD MAP, NON DESTRUCTIVE TESTING (NDT), CLEANING AND INSPECTION REPORTS TO BE PROVIDED BY MAZZEI.
- MAZZEI RECOMMENDS INSTALLING THE INJECTOR IN A HORIZONTAL POSITION. INJECTORS MAY BE INSTALLED IN A VERTICAL POSITION WITH THE LIQUID FLOW UPWARDS. HOWEVER, IN CERTAIN APPLICATIONS THIS MAY AFFECT PERFORMANCE. PLEASE REFER TO MAZZEI TECHNICAL BULLETIN No. 11; "MAZZEI INJECTOR INSTALLATION RECOMMENDATIONS FOR GAS TO LIQUID MIXING APPLICATIONS".

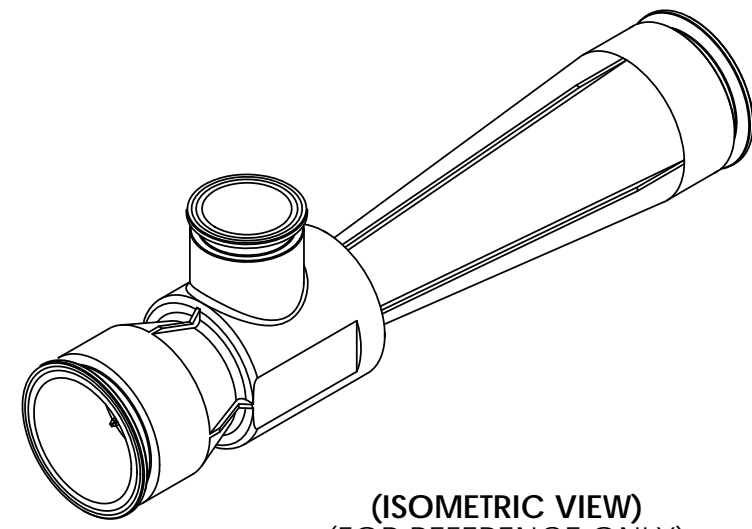

(ISOMETRIC VIEW)
(FOR REFERENCE ONLY)

SUBMITTAL DRAWING

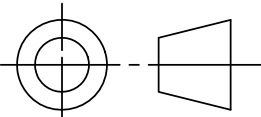
SUBMITTAL NOTICE		CONFIDENTIALITY NOTICE		UNLESS OTHERWISE SPECIFIED DIM ARE IN INCHES TOL ON ANGLE $\pm .1/2^\circ$ 1 PL $\pm .125$ 2 PL $\pm .060$ 3 PL $\pm .030$ INTERPRET DIM AND TOL PER ASME Y14.5M-1994		APPROVALS		DATE		 MAZZEI INJECTOR CO., LLC 500 ROOSTER DRIVE BAKERSFIELD, CA 93307 PHONE: (661) 363-6500 FAX: (661)363-7500 WWW.MAZZEI.NET					
ANY RECCOMENDATIONS FOR PRODUCT AND/OR SYSTEM DESIGN, WHETHER CONTAINED IN A DOCUMENT, WITHIN THIS DRAWING, COMMUNICATED BY ELECTRONIC MEANS OR GIVEN VERBALLY, ARE INTENDED SOLELY AS GUIDELINES TO ACTUAL SYSTEM DESIGN. SAID RECCOMENDATIONS ARE BASED UPON INFORMATION SUPPLIED BY OTHERS, THE ACCURACY OF WHICH IS BEYOND VERIFICATION BY MAZZEI INJECTOR CO. LLC. THEREFOR MAZZEI CANNOT AND DOES NOT WARRANT THE SUITABILITY OF ITS PRODUCTS FOR A PARTICULAR SERVICE NOR THE PERFORMANCE OF ANY SYSTEM CONTAINING COMPONENTS MADE OR SOLD BY MAZZEI.		THE INFORMATION CONTAINED IN THIS DRAWING IS THE SOLE PROPERTY OF MAZZEI INJECTOR COMPANY LLC. ANY REPRODUCTION IN PART OR AS A WHOLE WITHOUT THE WRITTEN PERMISSION OF MAZZEI IS STRICTLY PROHIBITED.		THIRD ANGLE PROJECTION 		DRAWN: T. JOHNS		6/5/2013				INJECTOR; MODEL SSC3090-M			
DRAWING MAY NOT BE PRINTED FULL SIZE DO NOT SCALE						CHECKED: J. MILLAN		6/3/2013		APPROVED: P. BANKOWSKI				6/5/2013	
				QA: -		CUSTOMER APPROVAL: -		SIZE: B		JOB NO.: NA		DRAWING NUMBER: SSC03090MBB00-SUB		REV: NC	
				CUSTOMER: NA		SCALE: NONE		WEIGHT: 15 LBS		SHEET: 1 OF 2					

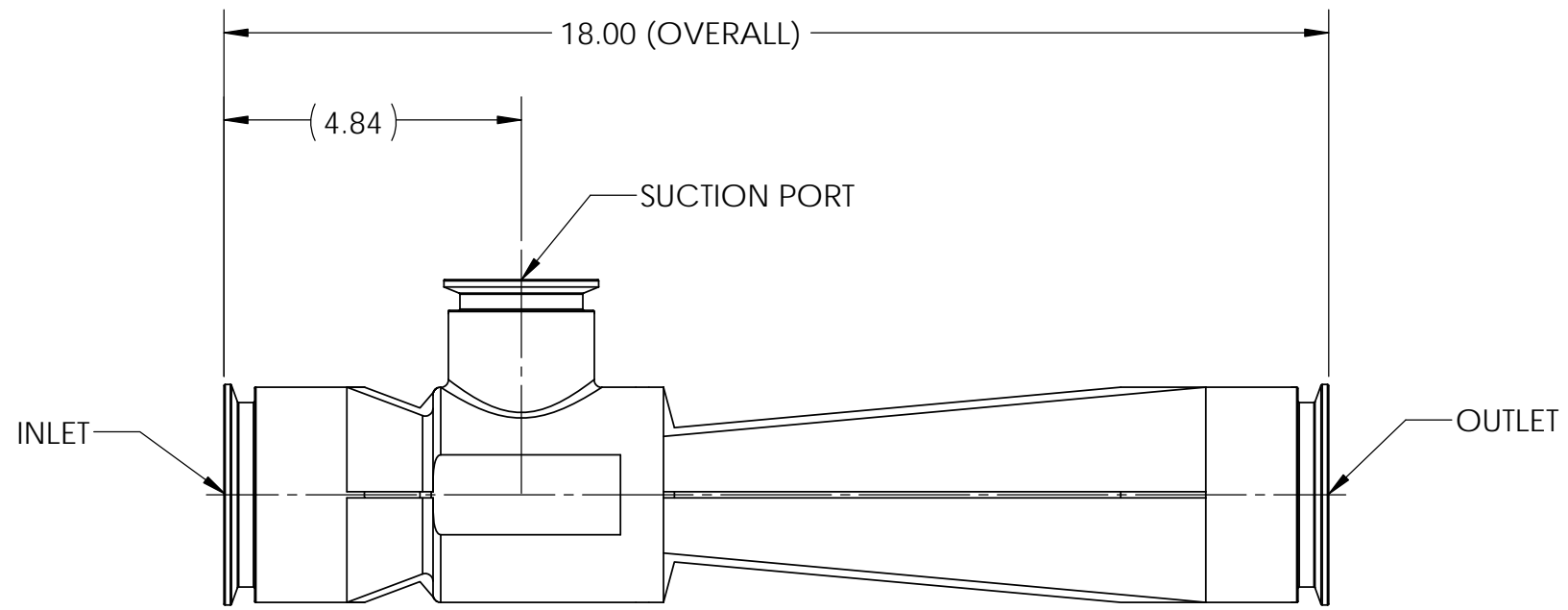

FLOW →
(SIDE VIEW)

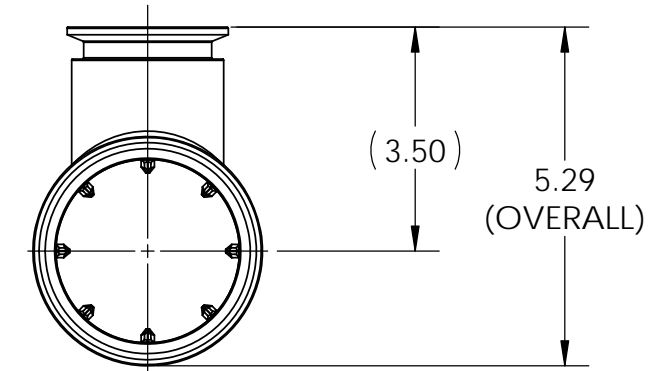

(END VIEW)

		MAZZEI INJECTOR CO., LLC 500 ROOSTER DRIVE BAKERSFIELD, CA 93307 PHONE: (661) 363-6500 FAX: (661) 363-7500 WWW.MAZZEI.NET		
		TITLE: INJECTOR; MODEL SSC3090-M		
SIZE:	JOB NO.:	DRAWING NUMBER:	REV:	
B	NA	SSC03090MBB00-SUB	NC	
SCALE:	WEIGHT:	SHEET:		
1:3	15 LBS	2 OF 2		