

NOTES:

1. INTERPRET DIMENSIONS AND TOLERANCES PER ASME Y14.5.

SPECIFICATIONS: OGS-20H

OXYGEN OUTPUT.....	20 SCFH @ 0 - 100 PSI 0.5 Nm ³ /hr @ 0 - 6.9 BAR
OXYGEN DEWPOINT.....	-60 °F (-51 °C)
OXYGEN PURITY.....	93 % ± 3 %
OXYGEN OUTLET FITTING.....	B SIZE OXYGEN ADAPTER
AIR INLET FITTING.....	NONE
FEED AIR REQUIREMENTS.....	N/A: COMPRESSOR INCLUDED
AIR QUALITY REQ.....	ISO 8573.1 CLASS 1.4.1 MINIMUM (SEE BELOW)
SOUND LEVELS:	
STANDARD	68 dBA @ 1 m
DIMENSIONS:	
STANDARD.....	40.1 in x 19 in x 45.6 in (WxDxH) (102 cm) x (48 cm) x (116 cm) (WxDxH)
APPROXIMATE WEIGHT:	
STANDARD.....	220 lb (99.7 kg)
POWER REQUIREMENTS:	
STANDARD (NORTH AMERICA).....	115 VAC, 60 Hz, SINGLE PHASE, 10 A
OPTIONAL (INTERNATIONAL).....	230 VAC, 50 Hz, SINGLE PHASE, 5 A
OPTIONAL (INTERNATIONAL).....	230 VAC, 60 Hz, SINGLE PHASE, 5 A
RESPONSE TIME.....	APPROXIMATELY 2 MINUTES TO ATTAIN MAXIMUM CONCENTRATION/PURITY AFTER INITIAL START-UP OR EXTENDED SHUTDOWN
POSITIONING.....	THE UNIT MUST BE OPERATED IN AN UPRIGHT POSITION ONLY, WITH NO OBSTRUCTION BLOCKING AIR FLOW AROUND THE UNIT. 6 IN MINIMUM CLEARANCE ON ALL SIDES.
SPECIFICATIONS: ISO 8573.1 CLASS 1.4.1	
DIRT PARTICLES 1-5 MICRON.....	0
WATER PRESSURE DEWPOINT	+37°F (940 PPM AT 100 PSIG)
OIL CONCENTRATION (INCLUDING VAPOR).....	0.01

* A STANDARD CUBIC FOOT (SCF) IS A CUBIC FOOT OF GAS AT 14.7 PSIA (SEA LEVEL ATMOSPHERIC PRESSURE) AND 60 °F

REV.	DESCRIPTION	DATE	APPR.	ECN
------	-------------	------	-------	-----

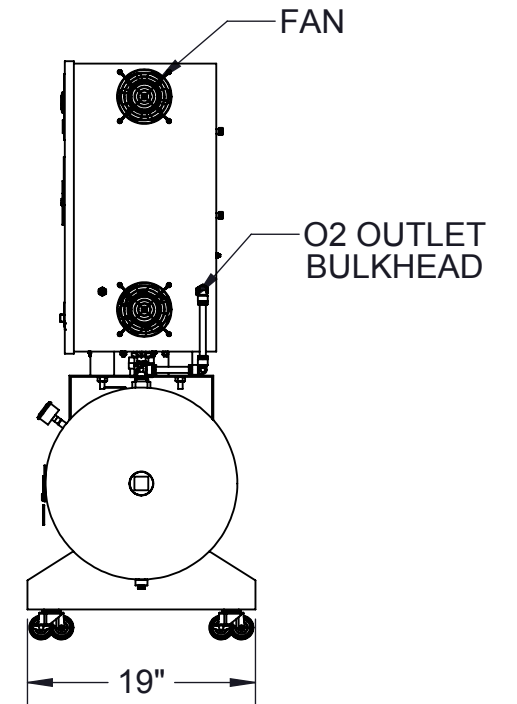
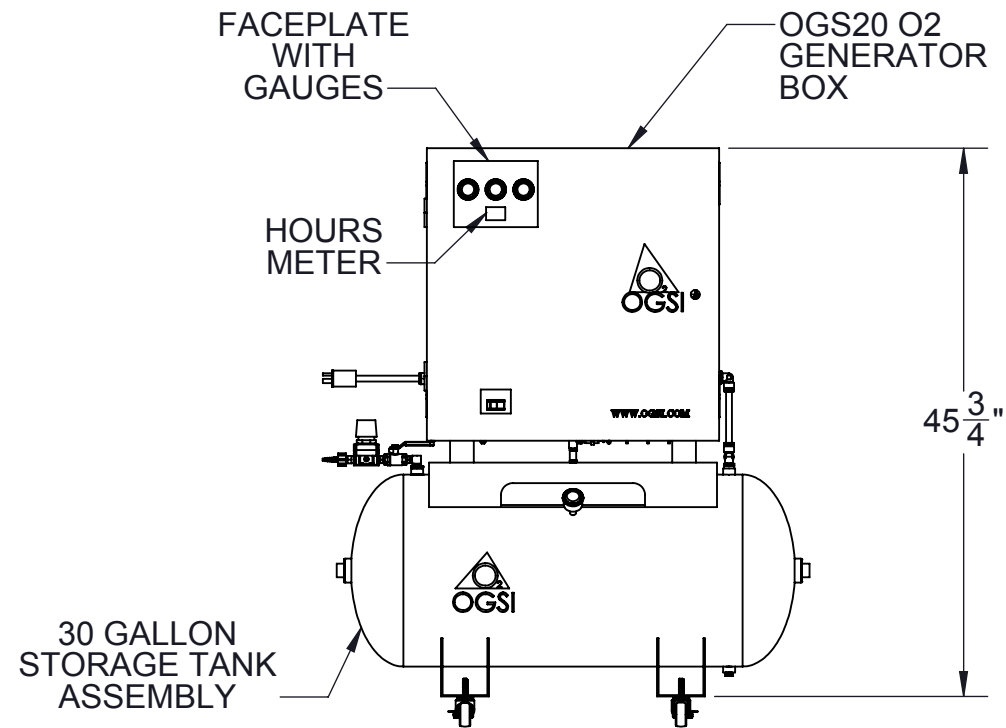
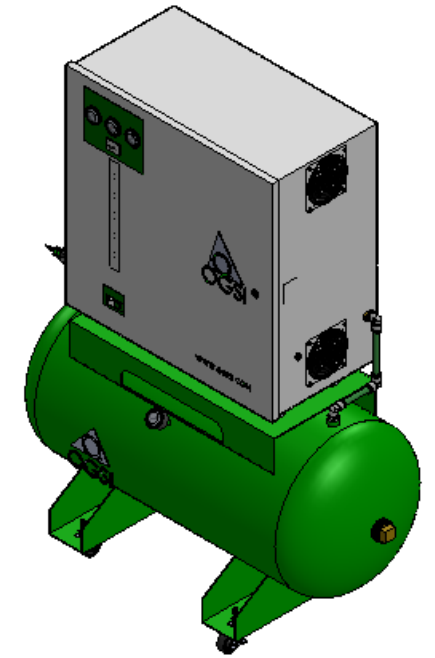
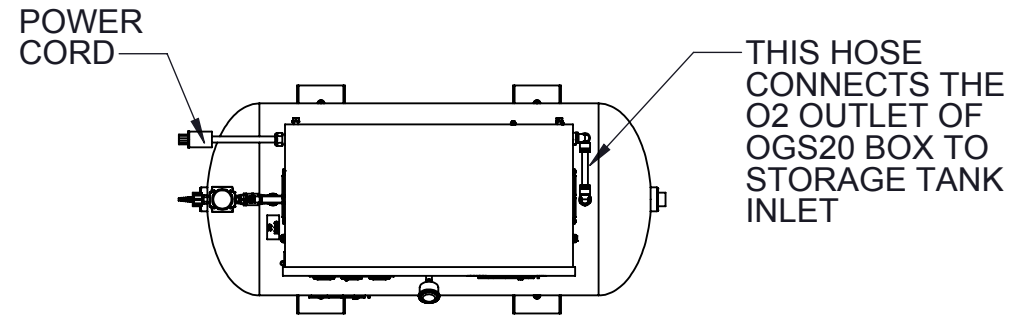

PROPRIETARY AND CONFIDENTIAL
All drawings, descriptions, prints, specifications, etc. bearing this notice, together with the information, and ideas contained therein, are the sole and exclusive property of Audubon Machinery Corp. Any disclosure or use thereof not authorized in writing by Audubon Machinery Corp. is unlawful and will be prosecuted to the full extent of the law.



DRAWN: T. MEYER	DATE: 10/18/13	PART NO: 10022		DRAWING TITLE: OGS20H & OGS20HT GENERAL ARRANGEMENT DRAWING	
CHKD: A. KAMBLE	DATE: 10/18/13	STOCK NO.	QTY.	DESCRIPTION	MATERIAL
UNLESS OTHERWISE SPECIFIED		REMOVE ALL BURRS AND BREAK SHARP EDGES 1/16" MAX			
DECIMALS: .XXX +/- .005		DO NOT SCALE DRAWING			
FRACTIONS: +/- 1/16		AUDUBON MACHINERY CORP. 814 Wurlitzer Dr., N. Tonawanda, NY 14120			
ANGLES: +/- 1°		SHEET: 1 OF 1			