



O & M Manual



Model C21 Gas Sampling System

Home Office

Analytical Technology, Inc.
6 Iron Bridge Drive
Collegetown, PA 19426
Phone: 800-959-0299
610-917-0991
Fax: 610-917-0992
Email: sales@analyticaltechnology.com
Web: www.Analyticaltechnology.com

European Office

ATI (UK) Limited
Unit 1 & 2 Gatehead Business Park
Delph New Road, Delph
Saddleworth OL3 5DE
Phone: +44 (0)1457-873-318
Fax: + 44 (0)1457-874-468
Email: sales@atiuk.com

Table of Contents

INTRODUCTION	4
SPECIFICATIONS.....	5
INSTALLATION.....	6
ELECTRICAL CONNECTIONS.....	7
INLET / OUTLET TUBING CONNECTIONS	8
INLET FILTER ASSEMBLY	8
OPERATION	9
FLOW TROUBLE ALARM.....	9
CONDENSATE DRAIN	9
MAINTENANCE	10
PERISTALTIC PUMP SERVICE	10
FAN AND INLET FILTER REPLACEMENT	11
SPARE PARTS	12

Table of Figures

<i>Figure 1 - Typical Installation</i>	<i>4</i>
<i>Figure 2 - Sampling System Enclosure Dimensions</i>	<i>6</i>
<i>Figure 3 - Power Connections</i>	<i>7</i>
<i>Figure 4 - Inlet Filter Assembly</i>	<i>8</i>
<i>Figure 5 - Condensate Pump.....</i>	<i>10</i>
<i>Figure 6 - Filter Replacement Removal Diagram.....</i>	<i>11</i>

INTRODUCTION

The model C21 is a gas sampling system that also includes a gas conditioning system. It is designed for gas measurement applications where high levels of moisture in the gas sample present problems for the gas sensors used in the measurement. In addition to simply pumping the gas sample, the C21 also removes moisture from the sample so that measurements can be done without condensation on sensors.

The C21 sampler contains 3 main elements, a long life diaphragm sample pump, a gas drying module, and a condensate removal pump. An internal rotameter provides operator adjustment of pump flow rate and a flow sensor provides an alarm in the event of loss of sample flow. Normal pumping rate for the C21 is 500 cc/minute.

Figure 1 below shows a typical C21 sampling system installation. The drawing shows a sampling system used in conjunction with an F12 gas transmitter, but the gas transmitter is shown in order to represent a typical system installation. No transmitter is supplied with the sampling system.

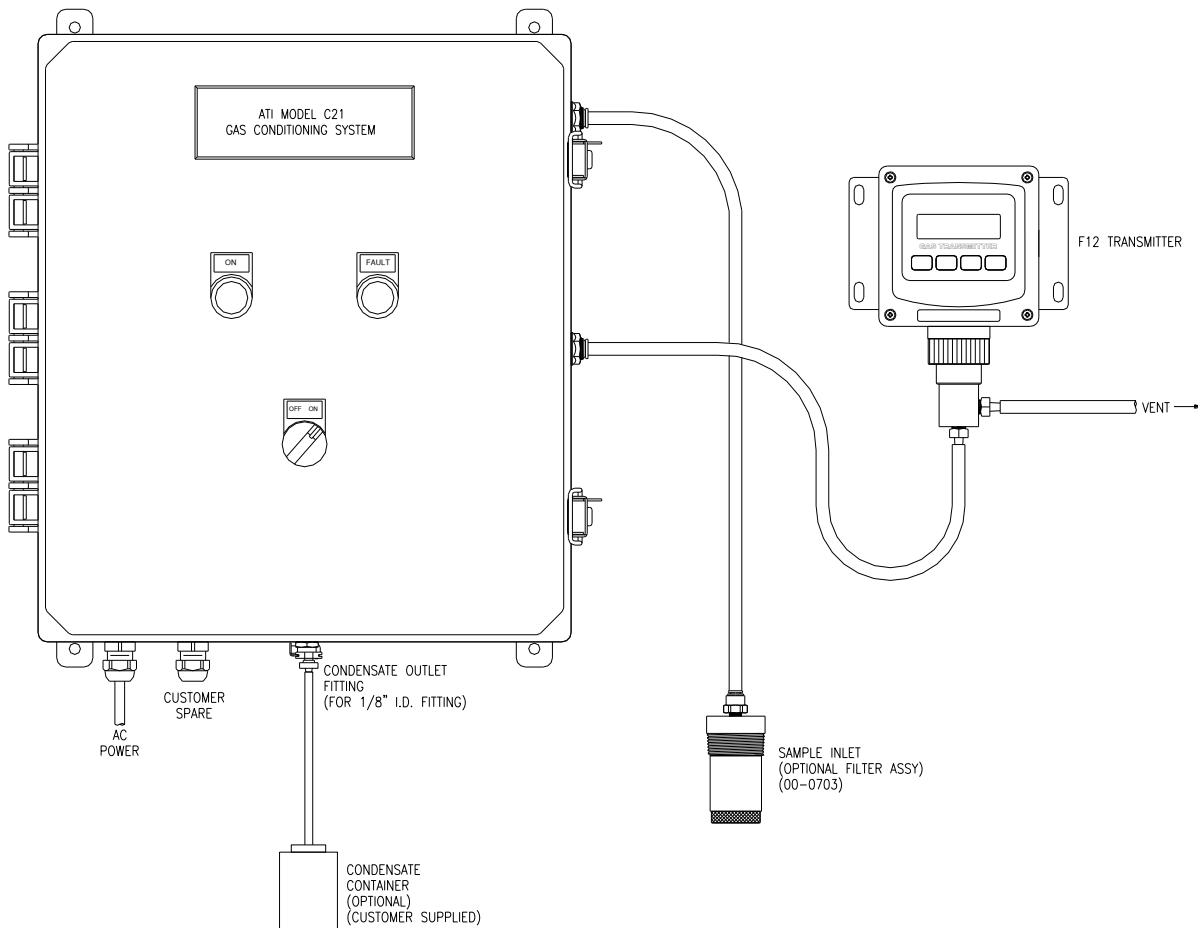

Figure 1 - Typical Installation

SPECIFICATIONS

System Power:	120 VAC, 50/60 Hz., 3 Amp Maximum, 240 VAC Optional
Gas Pump:	6 VDC Diaphragm Type, Brushless motor
Gas Flowrate:	500 cc./minute nominal, Adjustable 200-800 cc/minute
Sample Inlet:	Quick disconnect fitting for 1/8" I.D. tubing, Maximum 100 ft. (30 m.)
Sample Outlet:	Quick disconnect fitting for 1/8" I.D. tubing,
Condensate Pump:	Peristaltic with AC drive motor
Gas Dryer:	Electronic cold plate
Flow Indicator:	Acrylic Rotameter with stainless steel valve
Flow Alarm:	Red LED Alarm Indicator on enclosure front SPDT dry contact for external alarm indication.
Enclosure:	NEMA 2 / IP-52 Polycarbonate
Temperature:	Operating: -10° to +55° C Storage: -25° to +65° C
Size:	15" x 15" x 7" 380 x 380 x 178 mm
Weight:	25 lbs. (11.3 Kg.)

INSTALLATION

Installation of the C21 requires mounting the enclosure to a flat surface, connecting AC power to the terminal blocks inside the enclosure, and connection of inlet and outlet tubing.

Figure 2 provides the dimensional details for the sampling system enclosure. At least 12 inches of free space should be maintained to the left of the enclosure to allow the front section to open on its hinges.

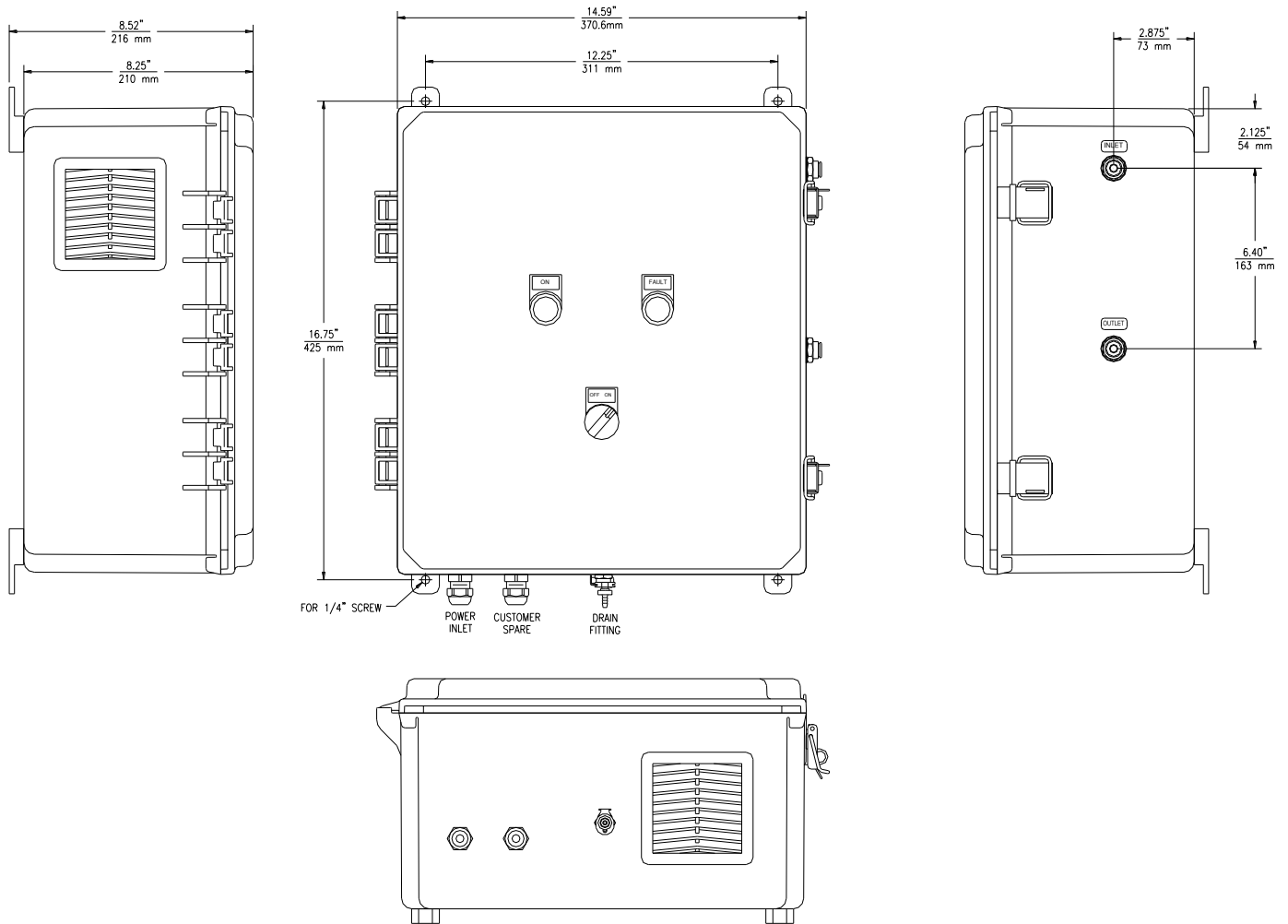

Figure 2 - Sampling System Enclosure Dimensions

Electrical Connections

AC power is connected to terminal blocks mounted in the sampling system. The L1 connection is made to a terminal block with a lever operated fuse holder. This block also serves to disconnect power should it be necessary. See Figure 3 for AC power connections. Note that the fuse lever must be opened in order to connect the hot line. Also note that the neutral and ground terminal blocks have two wire entries each. Incoming power wires connect to the upper terminal and use the front screw connection. Figure below is located inside enclosure.

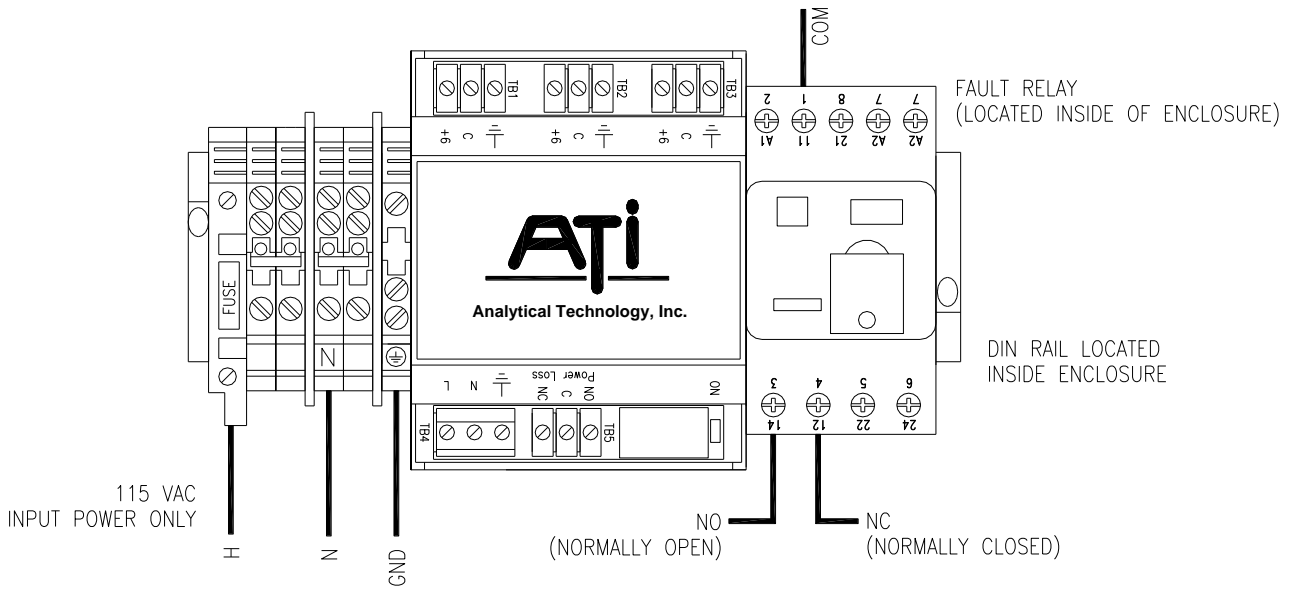

Figure 3 - Power Connections

Inlet / Outlet Tubing Connections

The sampling system contains hose barb connectors on the right side of the enclosure. The connection points are labelled on the outside of the enclosure. Inlet and outlet fittings are “push fit” type fittings designed for use with 1/4” O.D. tubing. Because every application is different in terms of tubing requirements, no tubing is supplied with the basic sampling system. Teflon lined PVC tubing is recommended and is normally ordered separately. Whatever tubing is ordered will be shipped with the sampling system. Alternative tubing materials can be used provided that they are compatible with the gases being sampled by the system.

Condensate from the sampling system is pumped out of the bottom of the enclosure. A connector on the bottom is supplied in the event that the condensate needs to be channeled to a collection container.

Inlet Filter Assembly

An inlet filter is available for use with the C21 sampling system. While this assembly is often not required, some applications may entail drawing samples from locations where filtration is needed. The filter can also serve to reduce water droplets from being pulled into the sample tubing. A replaceable membrane provides filtration down to less than 5 microns. The hydrophobic material will tend to shed water, especially when the holder is installed horizontally.

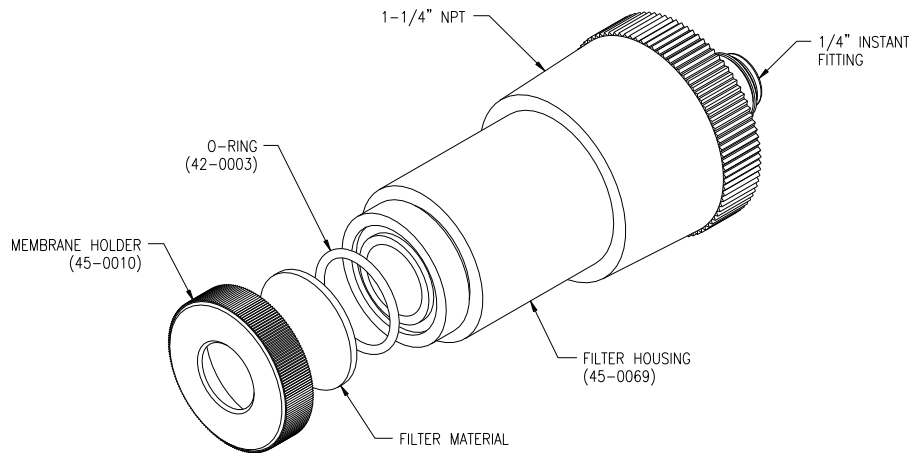

Figure 4 - Inlet Filter Assembly

The inlet filter assembly is designed for either insertion into a duct or pipe, or to simply hang in an enclosed space. A 1 1/4" NPT pipe thread is provided near the back of the housing to adapt to pipes or ducts. The rear of the housing contains a 1/4" I.D. soft tube fitting for sample line connection.

The filter replacement interval will depend on the severity of the application. Most applications will require replacement every 3-6 months, while very dirty locations may require replacement much more frequently. A package of 10 spare filters are supplied (part no. 05-0026).

OPERATION

Once AC power has been wired and the sample inlet and outlet tubing is connected, the system can be activated. An On/Off switch on the front door is used to activate the system. A green LED indicator light on the door comes on when power is turned on. The lever operated fuse holder can be used to turn power on or off inside the sampling system. As soon as power is switched on, the peristaltic pump will begin to operate.

Once power has been turned on, open the front door and observe the gas flowrate indicated on the rotameter in the center of the assembly. Use the knob on the rotameter to adjust the flow to 500 cc/min. This adjustment must be made with all inlet and outlet tubing connected in order to insure proper flow to the gas detection equipment.

Visually verify that the peristaltic condensate pump is operating. The slotted shaft on the pump head should be turning slowly and steadily.

Close and latch the front door. No other adjustments are required. Once the flow is set, the system is operational.

Flow Trouble Alarm

The sampling system contains a differential pressure switch that detects sample line blockage in the inlet or problems in the outlet line that cause a large backpressure on the pump outlet. If either of these conditions occur, the flow through the system will drop to a low value and the measurements on the outlet will not longer be useful.

Should one of these low flow conditions occur, a red alarm indicator light on the front of the system will illuminate and an internal relay will activate. One set of contacts on that relay are provided for external alarm indicators. The contacts are unpowered SPDT and can be connected to remote alarm indicators, PLC inputs, or other devices accepting a dry contact input. Shown below is the wiring for the external contact.

Operation of the flow alarm can be tested by briefly obstructing the inlet or outlet flow ports. Blocking the flow to either the inlet tube or the outlet tube should result in the red alarm indicator activating on the front door. The relay will also activate and an alarm should be seen at any remote devices wired to that relay.

Condensate Drain

In normal operation, excess water in the inlet gas sample is condensed on the surfaces of the sample conditioning module. The condensate is pumped out of the bottom of that device by the peristaltic pump directly below it. The amount of condensate will be variable depending on the humidity of the sample. You may see regular drops of water coming from the condensate pump or you may have times when no condensate is present at all.

If the sampling system is located outdoors, the condensate can probably just drip out onto the ground below. If the unit is mounted in a clean location, it may be necessary to place a container below the system to collect the condensate.

MAINTENANCE

Maintenance on a C21 gas sampling system should be done every 6 months. Peristaltic pump maintenance on the condensate pump is the only item in the system requiring periodic service. The sample dryer requires no maintenance. The gas sampling pump is normally maintenance free for at least a year or more.

The peristaltic condensate pump simply requires periodic tube replacement. Note that there are two tubes installed but only one is used in the standard sampling system. The second tube is installed to provide more uniform pressure plate tension and you do not need to change it.

The gas sampling pump contains a diaphragm and two valve assemblies. If the pump does not deliver the required 500 cc/min. flow, the diaphragm and valves should be changed. A replacement valve kit is available from ATI.

Should sampling system tubing become fouled over time, the best thing is to simply replace the tubing. It may be possible to clean the tubing but it is often difficult to do and replacement is a much easier solution to the problem.

Peristaltic Pump Service

Peristaltic pump tubing is supplied already cut to the correct length. Tubing should be changed every 6 months. The tube clamp assembly is spring loaded and is easily removed from the pump body. Tube holders slide out of the pump body and the tubes with fittings slide out of the tube holders. Simply pull the old tube off the fittings and install a new tube.

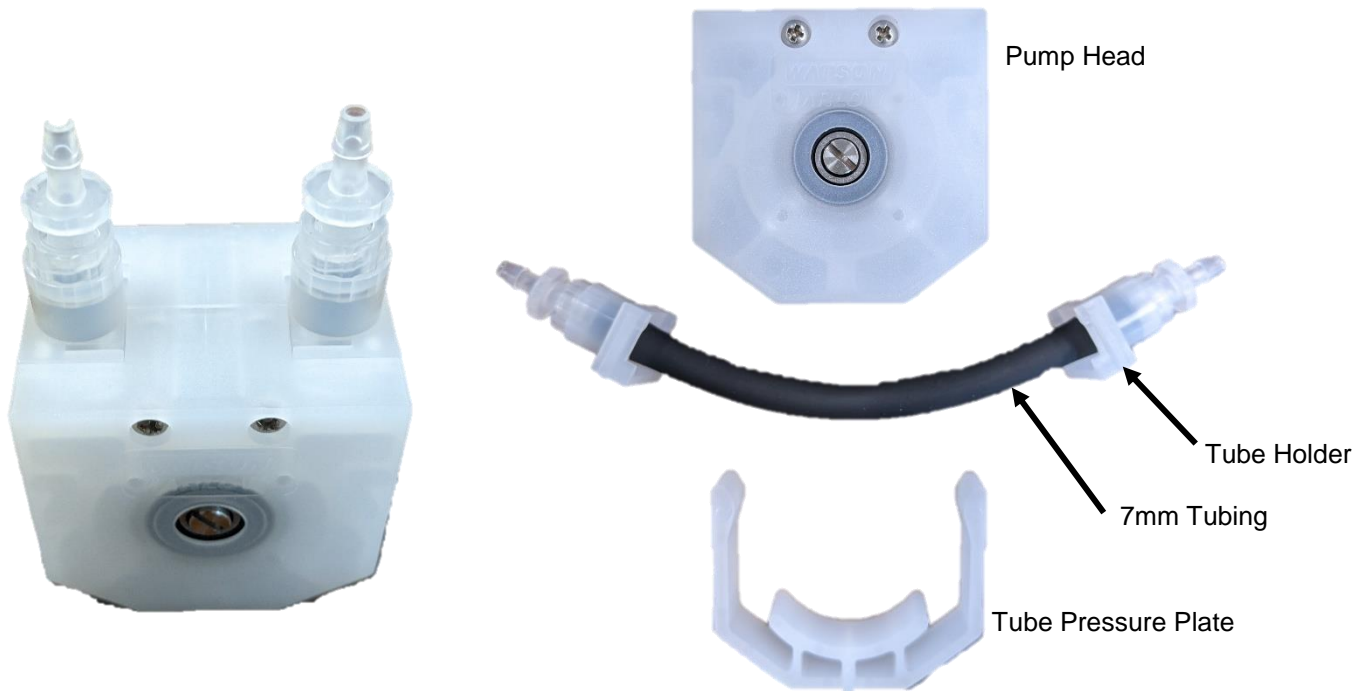

Figure 5 - Condensate Pump

Fan and Inlet Filter Replacement

Proper ventilation is critical for the operation of the sampling system. Excess heat buildup inside the enclosure will degrade the operation of the moisture removal system. A fan on the side of the enclosure continuously draws fresh air through the grill on the bottom and exhausts out the side. Filters are installed behind the plastic grills of both the inlet and the fan. These filters should be replaced every 3-6 months.

The grill can be removed by sliding it parallel to the enclosure side. The bottom of the grill has a small decal on it. Pull the grill from the bottom out a little then slide up to remove. Remove the filter material and replace it with a new one. Replace the grill.

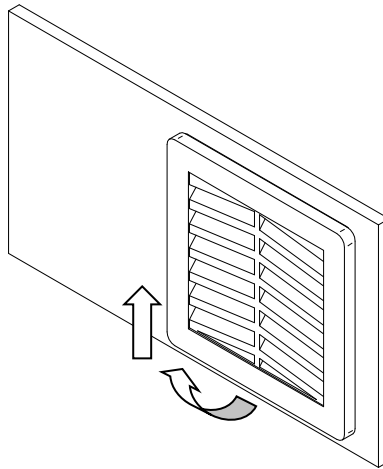

Figure 6 - Filter Replacement Removal Diagram

SPARE PARTS

<u>Part No.</u>	<u>Description</u>
03-0465	Sample Conditioning Module
00-1653	Power Supply Module, 6 VDC
23-0002	Fuse, 2A Slo-Blow
03-0423	Air Pump, 6 VDC
54-0017	Peristaltic Pump Head
36-0061	Peristaltic Pump Drive Motor, 120 VAC
36-0062	Peristaltic Pump Drive Motor, 230 VAC
36-0058	Fan with grill & filter, 120 VAC
36-0064	Fan with grill & filter, 230 VAC
36-0059	Inlet grill with filter
36-0063	Replacement filter, pkg of 6
26-0006	Pressure Switch
55-0014	Rotameter
25-0015	Relay Base
25-0016	Relay, 6 VDC Coil
26-0025	On/Off Switch
26-0024	On/Off Switch Contact Block
39-0008	Green LED Panel Light
39-0009	Red LED Panel Light
39-0010	Green LED Panel Light, 230V
39-0011	Red LED Panel Light, 230V
44-0360	Bulkhead Inlet/Outlet Fitting
44-0081	Bulkhead Condensate Drain Fitting
44-0036	Tube Fitting, 1/8" NPT x 1/8" ID, Rt. Angle
44-0159	Tube Fitting, 1/8" NPT x Luer
44-0167	Tube Fitting, 1/8" NPT x 1/8" ID
44-0168	Tube Fitting, Tee, 1/8" ID
44-0184	Fitting, Luer x 1/8" ID
44-0305	Quick Disconnect Fitting, drain
00-1711	Inlet Filter Assembly
45-0069	Inlet Filter Body
45-0010	Filter Cap for 00-1711
44-0290	Tube Fitting, 1/8" NPT x 1/4" OD
44-0124	Tygon/FEP Lined Tubing (per ft.)
05-0044	Peristaltic pump tubing kit, pkg. of 5
05-0026	Inlet assembly filters, package of 10

PRODUCT WARRANTY

Analytical Technology, Inc. (Manufacturer) warrants to the Customer that if any part(s) of the Manufacturer's equipment proves to be defective in materials or workmanship within the earlier of 18 months of the date of shipment or 12 months of the date of start-up, such defective parts will be repaired or replaced free of charge. Inspection and repairs to products thought to be defective within the warranty period will be completed at the Manufacturer's facilities in Collegeville, PA. Products on which warranty repairs are required shall be shipped freight prepaid to the Manufacturer. The product(s) will be returned freight prepaid and allowed if it is determined by the manufacturer that the part(s) failed due to defective materials or workmanship.

This warranty does not cover consumable items, batteries, or wear items subject to periodic replacement including lamps and fuses.

Gas sensors carry a 12 months from date of shipment warranty and are subject to inspection for evidence of misuse, abuse, alteration, improper storage, or extended exposure to excessive gas concentrations. Should inspection indicate that sensors have failed due to any of the above, the warranty shall not apply.

The Manufacturer assumes no liability for consequential damages of any kind, and the buyer by acceptance of this equipment will assume all liability for the consequences of its use or misuse by the Customer, his employees, or others. A defect within the meaning of this warranty is any part of any piece of a Manufacturer's product which shall, when such part is capable of being renewed, repaired, or replaced, operate to condemn such piece of equipment.

This warranty is in lieu of all other warranties (including without limiting the generality of the foregoing warranties of merchantability and fitness for a particular purpose), guarantees, obligations or liabilities expressed or implied by the Manufacturer or its representatives and by statute or rule of law.

This warranty is void if the Manufacturer's product(s) has been subject to misuse or abuse, or has not been operated or stored in accordance with instructions, or if the serial number has been removed.

Analytical Technology, Inc. makes no other warranty expressed or implied except as stated above.

WATER QUALITY MONITORS

Dissolved Oxygen
Free Chlorine
Combined Chlorine
Total Chlorine
Residual Chlorine Dioxide
Potassium Permanganate
Dissolved Ozone
pH/ORP
Conductivity
Hydrogen Peroxide
Peracetic Acid
Dissolved Sulfide
Residual Sulfite
Fluoride
Dissolved Ammonia
Turbidity
Suspended Solids
Sludge Blanket Level
MetriNet Distribution Monitor

GAS DETECTION PRODUCTS

NH ₃	Ammonia
CO	Carbon Monoxide
H ₂	Hydrogen
NO	Nitric Oxide
O ₂	Oxygen
CO	Cl ₂ Phosgene
Br ₂	Bromine
Cl ₂	Chlorine
ClO ₂	Chlorine Dioxide
F ₂	Fluorine
I ₂	Iodine
H _x	Acid Gases
C ₂ H ₄ O	Ethylene Oxide
C ₂ H ₆ O	Alcohol
O ₃	Ozone
CH ₄	Methane (Combustible Gas)
H ₂ O ₂	Hydrogen Peroxide
HCl	Hydrogen Chloride
HCN	Hydrogen Cyanide
HF	Hydrogen Fluoride
H ₂ S	Hydrogen Sulfide
NO ₂	Nitrogen Dioxide
NO _x	Oxides of Nitrogen
SO ₂	Sulfur Dioxide
H ₂ Se	Hydrogen Selenide
B ₂ H ₆	Diborane
GeH ₄	Germane
AsH ₃	Arsine
PH ₃	Phosphine
SiH ₄	Silane
HCHO	Formaldehyde
C ₂ H ₄ O ₃	Peracetic Acid
DMA	Dimethylamine