

CHECK OPERATION

Hold the sleeve down against the housing with one hand, and slowly ensure all components are lined up properly. As the piston travels up and down, it will also rock from side to side. This is a feature of the WOB-L piston.

REASSEMBLY:

STEP15: With the sleeves firmly seated on the housing, place the valve plate in same manner as it was before disassembly. Make sure the top edge of the sleeve locates in the O-ring groove in the bottom of the valve plate. Make sure the gasket is not twisted when seated in groove. **NOTE: Notch on valve plate faces opposite lead end.**

STEP 16: Place head on the valve plates, making sure the valve plate notch matches notch on head. Same orientation is as was before disassembly. Torque the head screws to 55 inlbs. in a crisscross pattern.

CAUTION: Always try rotating the fan by HAND prior to connecting the unit to the power source to avoid damage or injury. Check for suction at the air inlet port by placing your finger over the port as you turn the fan. You should feel a slight suction with each rotation of the fan. If you don't feel suction or you feel or hear a thump as you turn the fan, DO NOT CONNECT THE UNIT TO A POWER SOURCE; then review the assembly procedure for possible error.

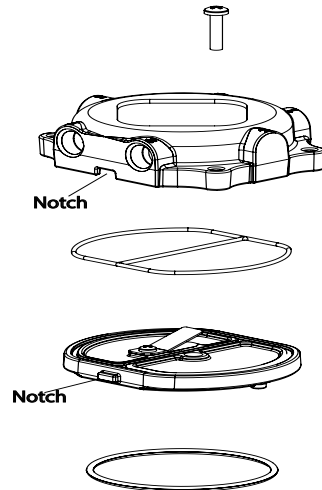

MODEL MP27 COMPRESSOR SERVICE KIT

WARNING: Unplug the compressor before beginning disassembly.

CAUTION: Improper assembly or use of damaged parts may lead to premature failure. To avoid frequent repairs follow the recommended assembly procedures.

This kit includes the following Parts:

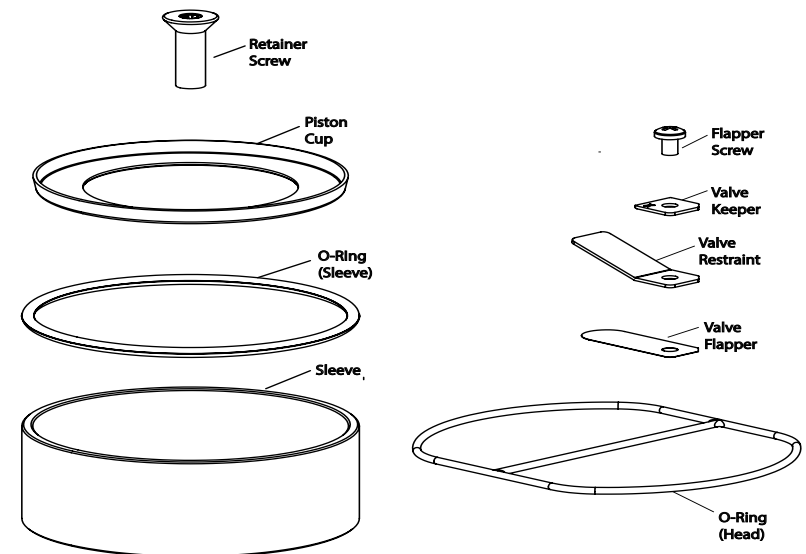

NOTE: Before you begin, read these instructions thoroughly and assemble the necessary tools. You will need:

- * 1/8" Hex drive for removal of retainer screw
- * #2 Phillips bit for removal of head and valve screws
- * 1/8" allen wrench bit for torque wrench (eccentric screw)
- * Torque wrench (18-55 inch pounds)
- * Flat screwdriver

STEP 1. Clean external surfaces of compressor.

STEP 2. Figure 1: Loosen and remove the 4 head screws (1) and remove the compressor head (2). **Note: If twin head compressor, loosen and remove the 8 head screws (4 on each side) and remove compressor head as one piece and then proceed to rework one side at a time.** Note the orientation of the head for reassembly (Intake and exhaust port locations). **Retain** head screws.

CAUTION: Place capacitor off to side leaving it connected to lead wires.

STEP 3. Carefully separate the valve plate (3) from the bottom of the head, or cylinder sleeve. Note orientation with respect to the tab on valve plate for reassembly.

STEP 4. Remove the head o-ring and sleeve o-ring and discard.

STEP 5. Figure 2: Remove the intake valve flapper, keeper, and screw from bottom of valve plate and discard. Clean plate with soft cloth. Install the new intake valve flapper, keeper (placed on top of flapper with "X" visible on top) and screw. **Note:** Torque flapper screws to 18 inch lbs.

STEP 6. Install the new O-ring, seating it firmly into the groove with your finger.

STEP 7: Remove the exhaust valve flapper, valve restraint and screw from the top of the valve plate and discard them. Clean the top of the plate with a clean, soft cloth. Install new exhaust valve flapper, valve restraint and screw. **Note:** Torque flapper screws to 18 inch lbs.

STEP 8: Install the new head o-ring, seating it firmly into the groove with your finger. Set aside valve plate assembly

Figure 1

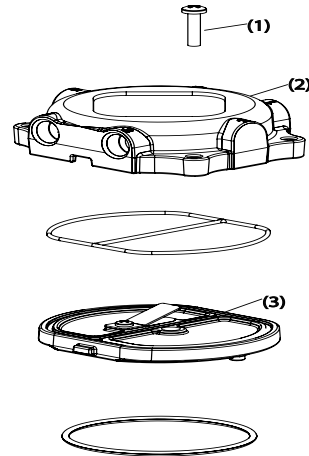
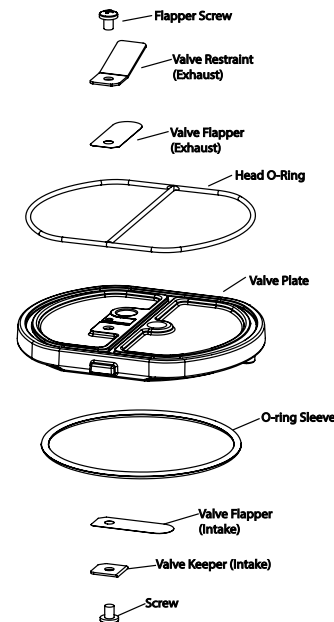

Figure 2:



STEP 9: Remove fan guard (pry off with flat screwdriver). Remove the fan by using two flat blade screwdrivers to pry off, making sure screwdriver contact is made with hub back and not the fan blades. Note fan orientation for reassembly. **Spring Clip In**

STEP 10: Figure 3: Insert the 5/32" hex wrench into the access hole in the compressor housing. Loosen the set screw 1/4 turn. Rotate connecting rod to top dead center (180 degree) and slide the connecting rod/eccentric assembly off the shaft and through the opening in the housing.

STEP 11: Figure 4: Secure the rod assembly in a fixture. Remove the sleeve (1) from the connecting rod and discard. Remove the screw (2) from the cup retainer (3). Discard screw only. Keep retainer for reassembly. Remove the piston cup (4) and discard. Wipe debris from the top of the connecting rod and retainer with a clean damp cloth.

STEP 12: Carefully place new sleeve (1) over connecting rod top. Place new cup (4) in center of connecting rod top. Do not damage the cup. Place retainer (3) on top of cup, making sure that the cup inside diameter is seated properly over retaining bosses. Note that the retainer has a locating boss that must insert into rod top pilot. Drive retainer screw to 55 inch lbs. Carefully push sleeve up forming the cup. Stop pushing the cylinder sleeve up when the piston cup is positioned midway inside the sleeve.

STEP 13: Rotate the rotor shaft so that the flat faces up (12:00). Position piston cup at bottom dead center of cylinder sleeve.

STEP 14: Slide the connecting rod assembly onto the shaft (counterweight facing up) until the eccentric face positively stops against the bearing. Align the eccentric set screw with the flat of the shaft. Rotate the eccentric and shaft 90 degrees so the set screw is visible thru the access hole in the housing, and tighten set screw to 125 inlbs.

STEP 15: Align the flat on the fan with the flat on the motor shaft and slide the fan back onto the motor shaft, making sure you position the fan clip in. Same orientation as it was before you removed it. Incorrect orientation of the fan will not provide adequate cooling of the compressor.

Figure 3

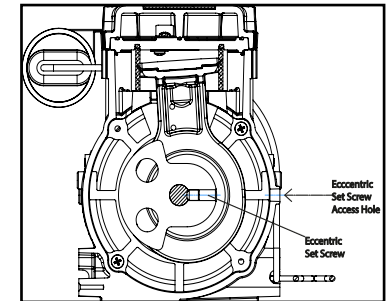

Figure 4

