



# OXG-60

## SPEC SHEET

# OXG TECHNOLOGY

The OXG Series are built with an Ozone Generation Cell and Oxygen Concentrator in one system. The OXG-60 can produce ozone at 60 g/hr from 10 LPM. These Ozone Generators are compact, efficient, and easy to use with a wide variety of options and features. Simply plug into electrical power and produce both oxygen and ozone from one unit.



## Main Features

- Can produce high concentrations of ozone at lower flow rates
- Integrated ozone leak sensor
- Integrated oxygen purity meter
- Adjustable ozone output

## Common Applications

- Water Treatment
- Bottled Water
- Laundry Applications
- Odor Control
- Agricultural Applications

# SYSTEM DIAGRAM

Standard OXG-60 Diagram

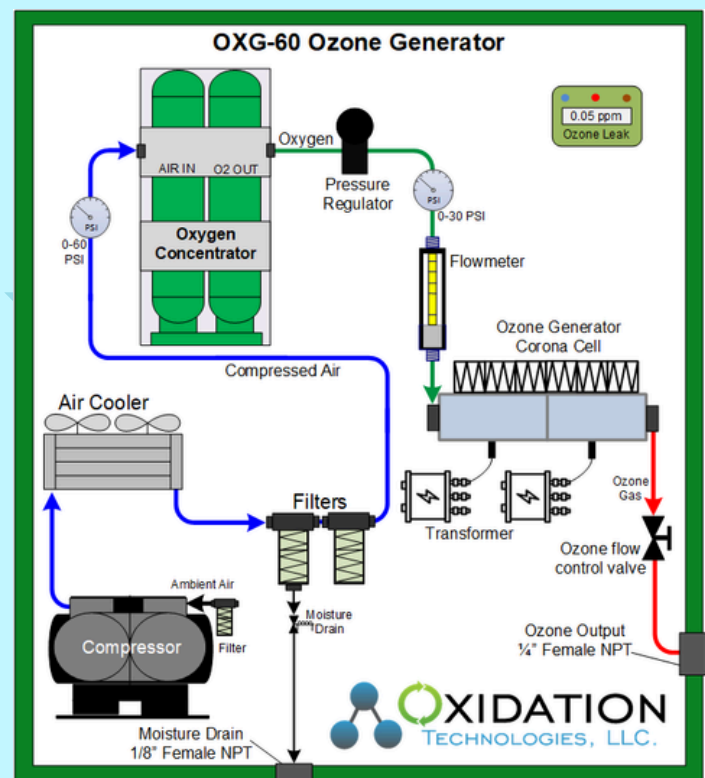
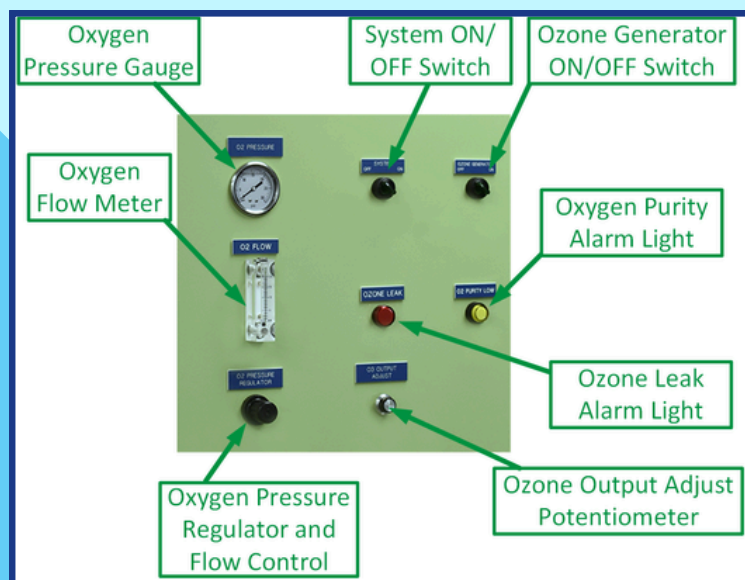

# OZONE PRODUCTION:

## Performance Chart

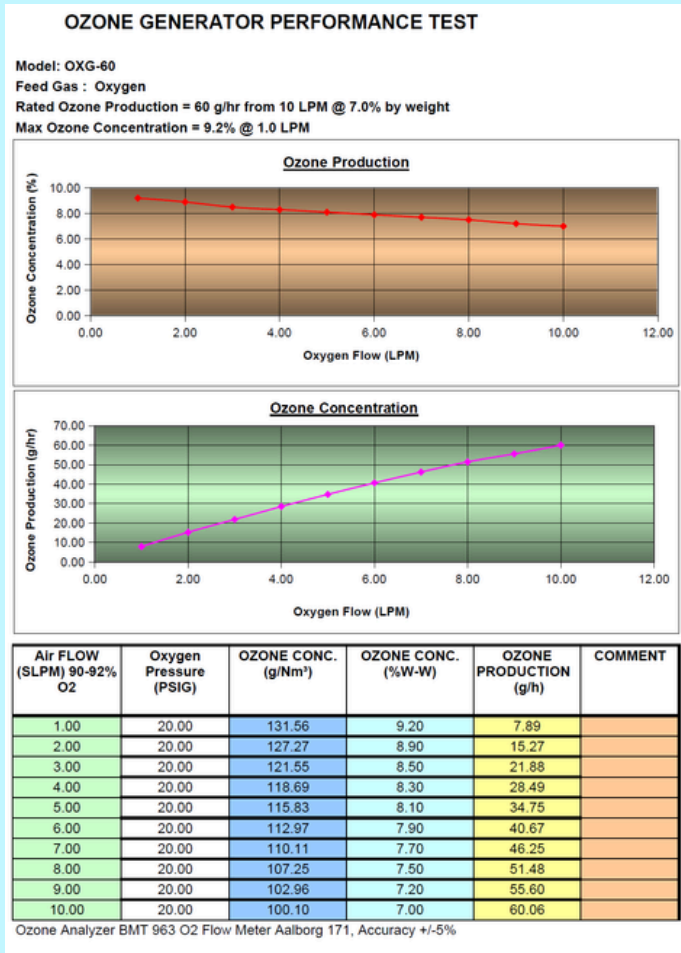

## Customizable Options

**Internal Compressed Air** - the standard OXG-60 to OXG-100 require plant compressed air for operation. An optional internal air compressor is available.

**Stainless Steel Enclosure** - Upgrade the enclosure to be stainless steel



## Product Specifications

Feed Gas	Built-in O2 Concentrator
Nominal Gas Flow Rate	10 LPM O2
Operating Pressure	10 - 20 PSI
Max Pressure	20 PSI
Cooling Method	Air Cooled
Corona Cell	Quartz, Stainless Steel
Gas Connections	1/4" NPT Fitting
Dimensions	12" x 31" x 36"
Temperature Range	35-95 deg F
Max O3 %	7.5% - 10%
Power	220 VAC, 60 Hz, 1-phase, 10amp
Ozone Output	60 g/hr

## CONTACT INFORMATION

If you need help with your ozone oxidation application, or have questions, please contact our team today.

Oxidation Technologies, LLC.  
 214 US Hw 18 Inwood, IA 51240  
 (515) 635-5854  
 Sales@oxidationtech.com  
 www.oxidationtech.com