

INSTRUCTIONS

for
INSTALLATION
OPERATION and MAINTENANCE

The right to make engineering refinements on all products is reserved. Dimensions and other details are subject to change.

POWERSTAT®

VARIABLE TRANSFORMERS
WITH POWERKOTE® COILS
116CU-40 / 116C / 117C / 216C and 217C Series

MOUNTING TEMPLATE NO. 1

NOTE: All dimensions are in inches [millimeters]

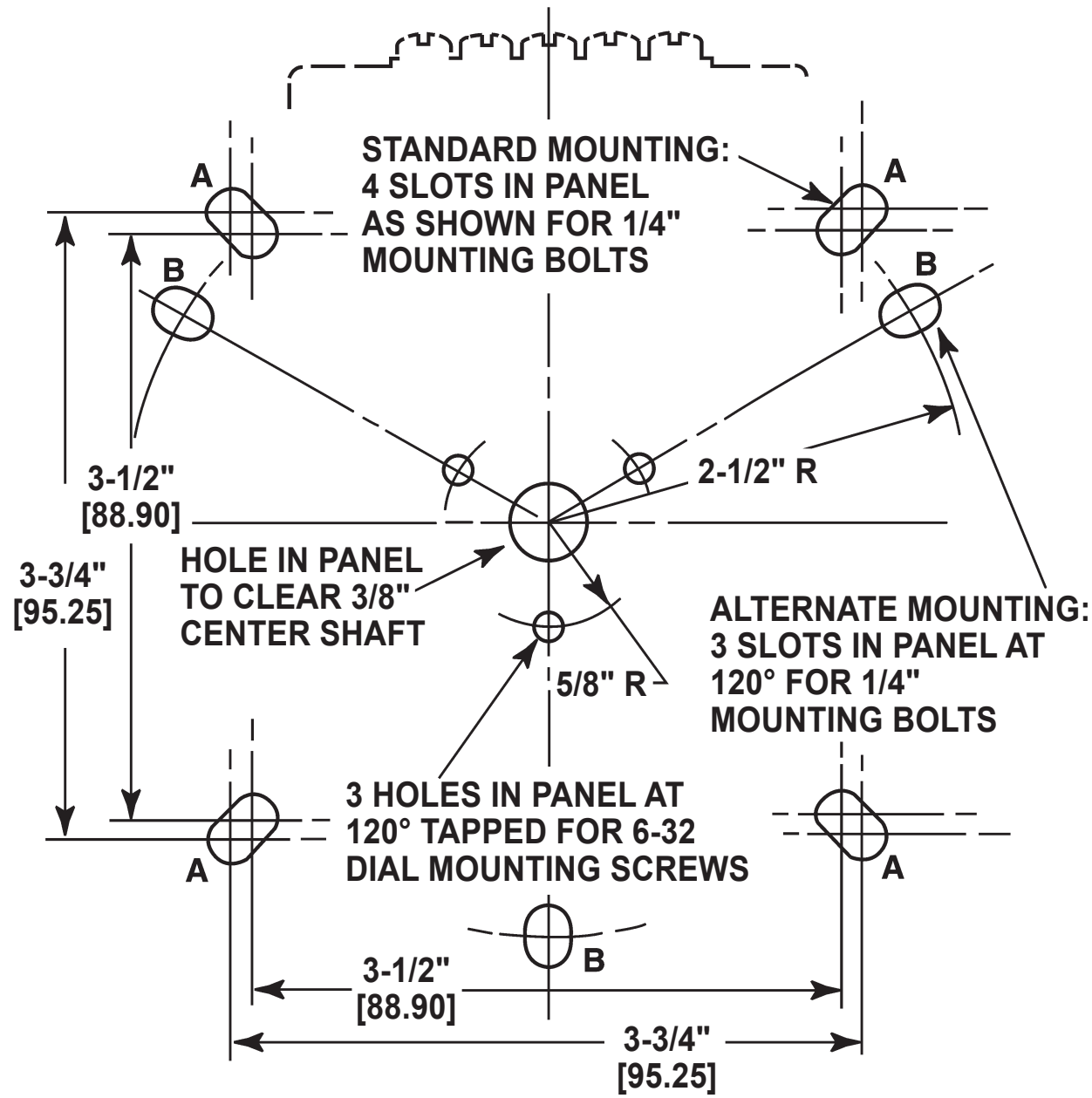

MOUNTING TEMPLATE NO. 2

NOTE: All dimensions are in inches [millimeters]

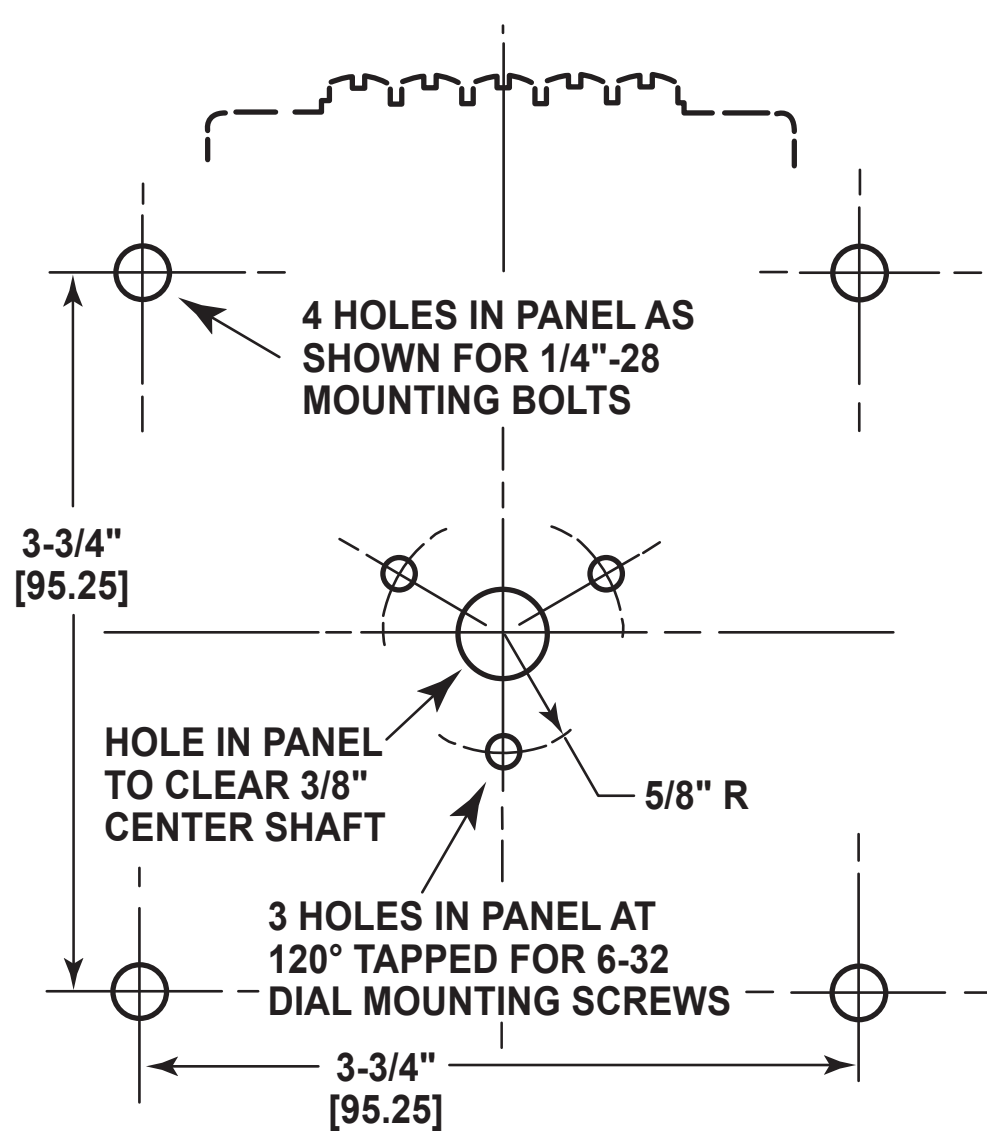

213709-063 REV H
©2021
ECN 97413

Telephone and Fax Numbers
Telephone 860-507-2025
Fax 860-507-2050

Toll-Free (in USA and Canada only)
Telephone 1-800-787-3532
Fax 1-800-821-1369

Email and Website
Email technical.support@superiorelectric.com
Website www.superiorelectric.com

2100 WEST BROAD STREET
ELIZABETHTOWN, NC 28337 USA

Printed in USA

INSPECTION

A POWERSTAT Variable Transformer is a precision product packed with care. When unpacking, examine carefully for any shipping damage. Inspect the brush contact with particular care. The "Damage and Shortage" Instructions packed with the unit outline the proper procedure to follow if any parts are damaged or missing.

INSTALLATION

NOTE: The unit should be protected from any dust or debris that may be encountered while drilling holes, installing wiring, etc. during installation.

MANUALLY OPERATED ASSEMBLIES

POWERSTAT Variable Transformer types within this Series have two sets of mounting holes to facilitate installation in new or existing layouts. Use the set that is most convenient for the application. All models are designed so that the same unit can be either bench or back-of-panel mounted as desired. The units as shipped are arranged for bench mounting. To change to back-of-panel mounting, proceed as outlined.

SINGLE UNITS

Models 3PN116C, 3PN117C, 3PN216C and 3PN217C have a cord and plug input and a receptacle output, and are usually used as a portable source of variable a-c voltage. If desired they may be mounted in the same manner as other manually operated single units.

BENCH OR WALL MOUNTING

- Using Drilling Template No. 1, locate and drill the desired set of mounting holes (four holes marked "A" or three holes marked "B").
- On open construction models ("U" types), loosen the shaft setscrews in the insulator of the radiator and slide the shaft through so it projects from the other end of the assembly. Tighten the setscrews.
- Place the unit in position and insert and fasten 1/4"-28 mounting screws.
- For "U" types, provide a support for the dial. Mount the dial to the support. Attach the knob with its pointer set correctly with respect to the brush location and the dial indications.
- In addition, on enclosed terminal ("T") types, remove the terminal cover and required conduit hole caps. Attach conduit or cable and dress the leads. Make the necessary connections to the terminal cover.

BACK-OF-PANEL MOUNTING

- Using Drilling Template No. 1, locate and drill the desired set of mounting holes (four holes marked "A" or three holes marked "B"), the three dial mounting screw holes, and the center shaft hole. Three dial screw holes must be tapped to accommodate the 6-32 screws supplied. Maximum panel thickness is 5/8" for open ("U" type) models.
- On enclosed models, remove the knob, loosen the shaft setscrews in the insulator of the radiator and slide the shaft through so it projects from the other end of the assembly. Tighten the setscrews. Maximum panel thickness for enclosed models is 5/16".

- Mount the dial on the front of the panel. Place the POWERSTAT Variable Transformer in the position behind the panel and insert and tighten 1/4" mounting screws.
- Attach the knob with the pointer set correctly with respect to the brush location and dial indications.

GANGED ASSEMBLIES

BENCH OR WALL MOUNTING

A. On Standoffs

- Using Drilling Template No. 2, locate and drill the four mounting holes.
- Remove the knob and dial, loosen the shaft setscrews in the insulator of each radiator and adjust the shaft so it projects from the radiator end of the assembly. Turn all of the radiators fully counterclockwise and tighten the shaft setscrews. Check to see that all brushes are in alignment.
- Place the unit in position and insert and fasten 1/4"-28 mounting bolts into the standoffs. Maximum bolt length is the panel thickness plus 3/8".
- Provide a support for the dial. Mount the dial to the support. Attach the knob with its pointer set correctly with respect to the brush location and the dial indications.

B. On Side Brackets

- Using Drilling Template No. 3, locate and drill the proper set of mounting holes.
- Insert two 1/4" mounting screws at one end of the assembly and screw down part way.
- Place the unit in position. Insert the other 1/4" screws and tighten all screws.

BACK-OF-PANEL MOUNTING

- Using Drilling Template No. 2, locate and drill the four mounting screw holes, the three dial mounting screw holes and the center shaft hole. The dial screw holes must be tapped to accommodate the 6-32 screws supplied. Maximum panel thickness is 3/4".
- Secure the dial in place. Place the assembly in position behind the panel and insert and tighten 1/4"-28 mounting screws. Mounting screw length should be the panel thickness plus 3/8".
- Provide a support in the form of a bench or cradle for the assembly.
- Attach the knob with the pointer set correctly with respect to the brush location and the dial indications.

MOTOR-DRIVEN ASSEMBLIES

Motor-driven POWERSTAT Variable Transformer types within this Series, both single units and ganged assemblies, may be bench or wall mounted in the same manner as manually operated ganged assemblies. Three-gang assemblies, however, have three side brackets requiring six bolts.

MAINTENANCE

With ordinary care, a POWERSTAT Variable Transformer should require no servicing except possible replacement of the brush assembly. The brush should be inspected periodically and replaced if arcing takes place or if it is badly worn. Because the brush must be of a special material, replace only with a Superior Electric brush assembly. The assembly is designed to assure perfect contact of the brush to the commutator regardless of brush position and length of time in use. Take care to avoid scraping, scratching or marring the commutator surface. Follow these steps to install a new brush assembly:

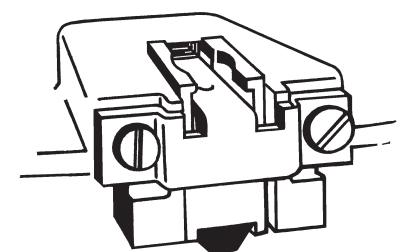

FIGURE A
BRUSH ASSEMBLY

- Unfasten the two brush anchor screws, remove and discard the old brush assembly.
- Insert the new brush assembly. Be sure that the tang on the back of the brush assembly goes under the overhang at the rear of the radiator slot. Replace and tighten the brush anchor screws.
- Raise the brush and place a piece of sandpaper (grit #400 or finer) between the brush and the commutator with the abrasive side against the brush.
- While holding the sandpaper in place (flat), rotate the brush through a short arc about four times. Remove the sandpaper and blow out any remaining carbon particles.
- Rotate the brush over the full range several times to check for smooth travel and to be sure the brush fits flat to the commutator over the full range.

REPLACEMENT BRUSH ASSEMBLIES

TYPE	PART NO.	DESCRIPTION
116CU-40	065431-004	RB116C-40
116C / 117C	065431-001	RB116C/RB117C
216C / 217C	065431-002	RB216C/RB217C

Whenever unusual mechanical or electrical difficulties are encountered in the operation or installation of your POWERSTAT Variable Transformer, consult Superior Electric.

CONNECTIONS AND RATINGS

Important connection notes. Please read carefully.

- CONNECTIONS AND RATINGS given in these instructions are those most commonly used. In addition, all ganged units may be connected so that the units operate electrically independent on a common shaft. When this is desired, connections and ratings for the individual models may be obtained from the RATINGS CHART and CONNECTION DIAGRAMS of the single unit.
- Coil to terminal connections for all POWERSTAT Variable Transformers included in these instructions are given in Figures B, C, and D.
- For ambient temperatures between -20°C and +50°C use current ratings given in the charts. Figure E shows the output current de-rating required above 50°C.
- The connection diagrams are labeled "L" for Line Connections, "B" for Boost Connections and "S" for Step-Up Connections.
- Clockwise (CW) and counterclockwise (CCW) rotation connections shown in the tables and diagrams are for motor driven units and units with the knob on the radiator end. For connections with the knob on the base end, use the shown CCW connection for CW operation, and shown CW connection for CCW operation.

- For the Step-Up Connections the tables show maximum output current rating for output voltages up to 125% of the input voltage, and maximum KVA at maximum output voltage. The output current must be reduced according to the curve in Figure F for output voltages greater than 125% of input voltage. Maximum KVA may be calculated using the rating curve in Figure F for voltages less than maximum.
- Motor drive wiring is shown in Figure G.
- Fuses are recommended on all units as shown (S) and are supplied on cord-and-plug 3PN116C (10 ampere), 3PN117C (15 ampere), 3PN216C (4 ampere) and 3PN217C (8 ampere) models. For all other models, see Figure H for recommended fuse ratings.
- COMMON shown in the connection diagrams is used as third leg in 3-phase open delta, or neutral in single-phase 3-wire and 3-phase 4-wire wye configurations. COMMON is not used in single-phase 2-wire or 3-phase 3-wire wye configurations. Jumper(s) provided in standard common position should be moved or removed as required.
- Cord-and-plug models 3PN116C and 3PN216C are wired in the Boost "B" Connection when shipped.
- Use connection wires suitable for at least 90°C.

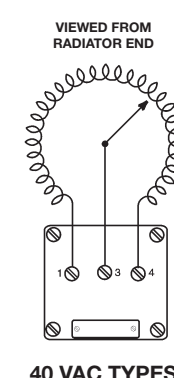

40 VAC TYPES
FIGURE B

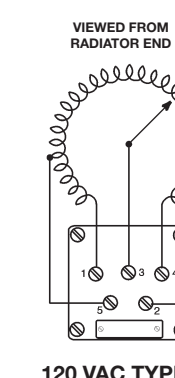

120 VAC TYPES
FIGURE C

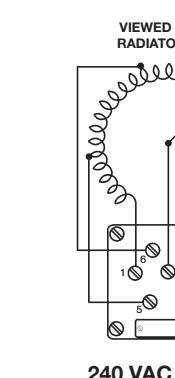

240 VAC TYPES
FIGURE D

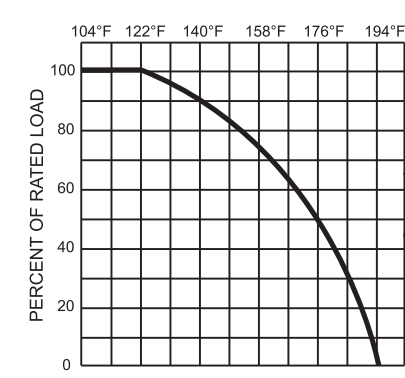
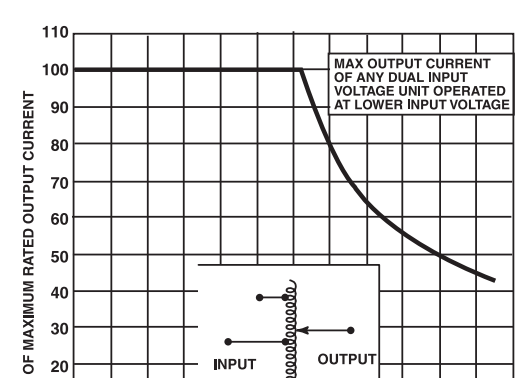
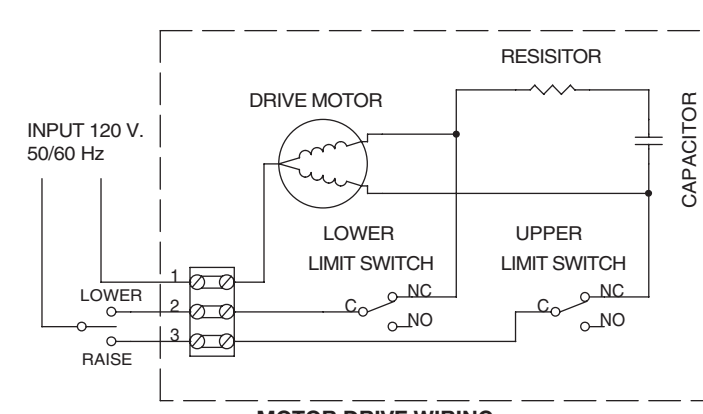

FIGURE E



OPERATION IN "STEP-UP" CONNECTION
FIGURE F



MOTOR DRIVE WIRING
FIGURE G

BASIC UNIT TYPE	RECOMMENDED FUSE (AMPERES)	
	CONSTANT CURRENT LOAD	CONSTANT IMPEDANCE LOAD
116CU-40	25	30
116C	10†	15
117C	15	15†
216C	4†	5
217C	5	8†

† Cord-and-Plug units supplied with these fuses

FIGURE H

Motor Driven Prefix shown below:		
Model Number	Operating Time for Full Travel (seconds)	
Prefix	60 Hz	50 Hz
7ME	7	8
15ME	15	18
30ME	30	36
60ME	60	72

FIGURE I

CONNECTION DIAGRAMS

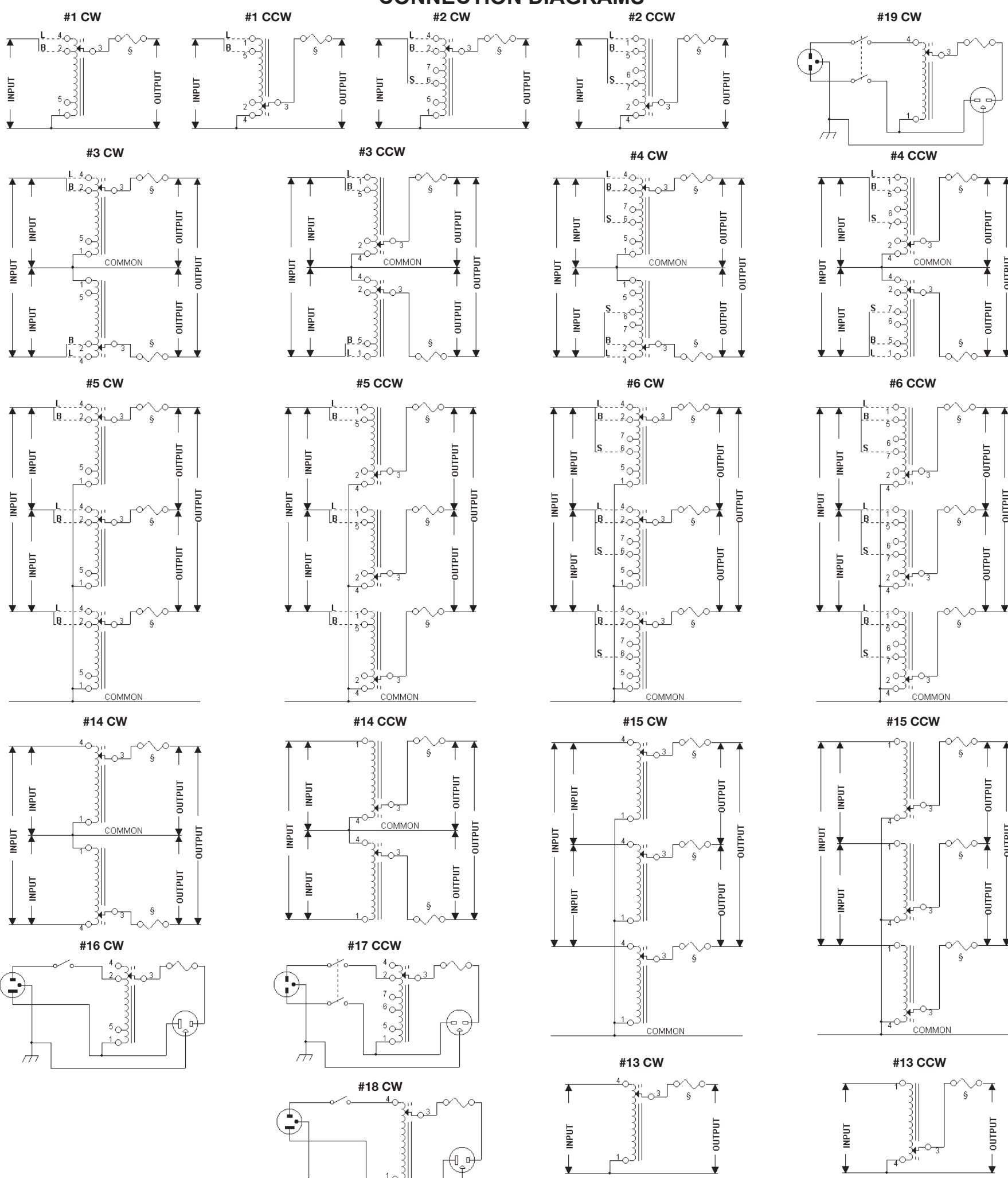

RATINGS CHART

40 VOLT, SINGLE PHASE																
"LINE" CONNECTION				"BOOST" CONNECTION				"STEP-UP" CONNECTION				Model Numbers				
Input Voltage:		Output Voltage:		Constant Current Load		Constant Impedance Load		Terminals & Rotation		Constant Current Load		Terminals & Rotation		Manually Operated	Motor Driven (See Fig. I)	Conn. Diag.
Freq. (Hz)	Max. Amps	Max. KVA	Max. Amps	Max. KVA	Input CW	Output CW	Jumper CW	Freq. (Hz)	Max. Amps	Max. KVA	Input CW	Output CW	Jumper CW	116CU-40	ME116CU-40	13
60	25	1.0	30	1.2	1-4	1-3	3-4									
120 VOLT, SINGLE PHASE																
"LINE" CONNECTION				"BOOST" CONNECTION				"STEP-UP" CONNECTION				Model Numbers				
Input Voltage:		Output Voltage:		Constant Current Load		Constant Impedance Load		Terminals & Rotation		Constant Current Load		Terminals & Rotation		Manually Operated	Motor Driven (See Fig. I)	Conn. Diag.
Freq. (Hz)	Max. Amps	Max. KVA	Max. Amps	Max. KVA	Input CW	Output CW	Jumper CW	Freq. (Hz)	Max. Amps	Max. KVA	Input CW	Output CW	Jumper CW	3PN116C	ME116CU	16
50/60	10	1.2	13	1.6	1-4	1-3	3-4	50/60	10	1.4	1-2	1-3	3-4	116CU	ME116CT	1
60	12	1.4	15	1.8	1-4	1-3	3-4						3PN117C	ME117CU	18	
														117CU	ME117CT	13
240 VOLT, SINGLE PHASE																
"LINE" CONNECTION				"BOOST" CONNECTION				"STEP-UP" CONNECTION				Model Numbers				
Input Voltage:		Output Voltage:		Constant Current Load		Constant Impedance Load		Terminals & Rotation		Constant Current Load		Terminals & Rotation		Manually Operated	Motor Driven (See Fig. I)	Conn. Diag.
Freq. (Hz)	Max. Amps	Max. KVA	Max. Amps	Max. KVA	Input CW	Output CW	Jumper CW	Freq. (Hz)	Max. Amps	Max. KVA	Input CW	Output CW	Jumper CW	3PN216C	ME216CU	17
50/60	3.5	0.84	5	1.2	1-4	1-3	3-4	50/60	3.5	0.98	1-2	1-3	3-4	216CU	ME216CT	2
60	5	1.2	7	1.7	1-4	1-3	3-4						3PN217C	ME217CU	19	
50/60	10	2.4	13	3.1	4-4	3-3	1-1	50/60	10	2.8	2-2	3-3	1-1	217CU	ME217CU	13
60	12	2.9	15	3.6	4-4	3-3	1-1						116CU-2	ME116CU-2	3	
														117CU-2	ME117CU-2	14
480 VOLT, SINGLE PHASE																
"LINE" CONNECTION				"BOOST" CONNECTION				"STEP-UP" CONNECTION				Model Numbers				
Input Voltage:		Output Voltage:		Constant Current Load		Constant Impedance Load		Terminals & Rotation		Constant Current Load		Terminals & Rotation		Manually Operated	Motor Driven (See Fig. I)	Conn. Diag.
Freq. (Hz)	Max. Amps	Max. KVA	Max. Amps	Max. KVA	Input CW	Output CW	Jumper CW	Freq. (Hz)	Max. Amps	Max. KVA	Input CW	Output CW	Jumper CW	216CU-2 <th>ME216CU-2 <th>4 </th></th>	ME216CU-2 <th>4 </th>	4
50/60	3.5	1.7	5	2.4	4-4	3-3	1-1	50/60	3.5	2.0	2-2	3-3	1-1	217CU-2	ME217CU-2	14
60	5	2.4	7	3.4	4-4	3-3	1-1									
600 VOLT, SINGLE PHASE																
"LINE" CONNECTION				"BOOST" CONNECTION				"STEP-UP" CONNECTION				Model Numbers				
Input Voltage:		Output Voltage:		Constant Current Load		Constant Impedance Load		Terminals & Rotation		Constant Current Load		Terminals & Rotation		Manually Operated	Motor Driven (See Fig. I)	Conn. Diag.
Freq. (Hz)	Max. Amps	Max. KVA	Max. Amps	Max. KVA	Input CW	Output CW	Jumper CW	Freq. (Hz)	Max. Amps	Max. KVA	Input CW	Output CW	Jumper CW	216CU-2 <th>ME216CU-2 <th>4 </th></th>	ME216CU-2 <th>4 </th>	4
60	3.5	2.1	5	3.0	4-4	3-3	1-1									
120 VOLT, THREE PHASE OPEN DELTA																
"LINE" CONNECTION				"BOOST" CONNECTION				"STEP-UP" CONNECTION				Model Numbers				
Input Voltage:		Output Voltage:		Constant Current Load		Constant Impedance Load		Terminals & Rotation		Constant Current Load		Terminals & Rotation		Manually Operated	Motor Driven (See Fig. I)	Conn. Diag.
Freq. (Hz)	Max. Amps	Max. KVA	Max. Amps	Max. KVA	Input CW	Output CW	Jumper CW	Freq. (Hz)	Max. Amps	Max. KVA	Input CW	Output CW	Jumper CW	116CU-2 <th>ME116CU-2 <th>3 </th></th>	ME116CU-2 <th>3 </th>	3
50/60	10	2.1	13	2.7	4-1-4	3-1-3	1-1	50/60	10	2.4	2-1-2	3-1-3	1-1	117CU-2	ME117CU-2	14
60	12	2.5	15	3.1	4-1-4	3-1-3	1-1									
240 VOLT, THREE PHASE OPEN DELTA																
"LINE" CONNECTION				"BOOST" CONNECTION				"STEP-UP" CONNECTION				Model Numbers				
Input Voltage:		Output Voltage:		Constant Current Load		Constant Impedance Load		Terminals & Rotation		Constant Current Load		Terminals & Rotation		Manually Operated	Motor Driven (See Fig. I)	Conn. Diag.
Freq. (Hz)	Max. Amps	Max. KVA	Max. Amps	Max. KVA	Input CW	Output CW	Jumper CW	Freq. (Hz)	Max. Amps	Max. KVA	Input CW	Output CW	Jumper CW	216CU-2 <th>ME216CU-2 <th>4 </th></th>	ME216CU-2 <th>4 </th>	4
50/60	3.5	1.5	5	2.1	4-1-4	3-1-3	1-1	50/60	3.5	1.7	2-1-2	3-1-3	1-1	217CU-2	ME217CU-2	14
60	5	2.1	7	2.9	4-1-4	3-1-3	1-1									
240V/138 VOLT, THREE PHASE WYE																
"LINE" CONNECTION				"BOOST" CONNECTION				"STEP-UP" CONNECTION				Model Numbers				
Input Voltage:		Output Voltage:		Constant Current Load		Constant Impedance Load		Terminals & Rotation		Constant Current Load		Terminals & Rotation		Manually Operated	Motor Driven (See Fig. I)	Conn. Diag.
Freq. (Hz)	Max. Amps	Max. KVA	Max. Amps	Max. KVA	Input CW	Output CW	Jumper CW	Freq. (Hz)	Max. Amps	Max. KVA	Input CW	Output CW	Jumper CW	116CU-3 <th>ME116CU-3 <th>5</th> </th>	ME116CU-3 <th>5</th>	5
50/60	10	4.2	13	5.4	4-4-4	3-3-3	1-1-1	60	10	4.8	2-2-2	3-3-3	1-1-1	117CU-3	ME117CU-3	15
60	12	5.0	15	6.2	4-4-4	3-3-3	1-1-1									
480V/277 VOLT, THREE PHASE WYE																
"LINE" CONNECTION				"BOOST" CONNECTION				"STEP-UP" CONNECTION				Model Numbers				
Input Voltage:		Output Voltage:		Constant Current Load		Constant Impedance Load		Terminals & Rotation		Constant Current Load		Terminals & Rotation		Manually Operated	Motor Driven (See Fig. I)	Conn. Diag.
Freq. (Hz)	Max. Amps	Max. KVA	Max. Amps	Max. KVA	Input CW	Output CW	Jumper CW	Freq. (Hz)	Max. Amps	Max. KVA	Input CW	Output CW	Jumper CW	216CU-3 <th>ME216CU-3 <th>6</th> </th>	ME216CU-3 <th>6</th>	6
50/60	3.5	2.9	5	4.2	4-4-4	3-3-3	1-1-1	60	3.5	3.4	2-2-2	3-3-3	1-1-1	217CU-3	ME217CU-3	15
60	5	4.2	7	5.8	4-4-4	3-3-3	1-1-1									
600V/346 VOLT, THREE PHASE WYE																
"LINE" CONNECTION				"BOOST" CONNECTION				"STEP-UP" CONNECTION				Model Numbers				
Input Voltage:		Output Voltage:		Constant Current Load		Constant Impedance Load		Terminals & Rotation		Constant Current Load		Terminals & Rotation		Manually Operated	Motor Driven (See Fig. I)	Conn. Diag.
Freq. (Hz)	Max. Amps	Max. KVA	Max. Amps	Max. KVA	Input CW	Output CW	Jumper CW	Freq. (Hz)	Max. Amps	Max. KVA	Input CW	Output CW	Jumper CW	216CU-3 <th>ME216CU-3 <th>6</th> </th>	ME216CU-3 <th>6</th>	6
60	3.5	3.6	5	5.2	4-4-4	3-3-3	1-1-1									

MOUNTING TEMPLATE NO. 3

NOTE: All dimensions are in inches [millimeters]

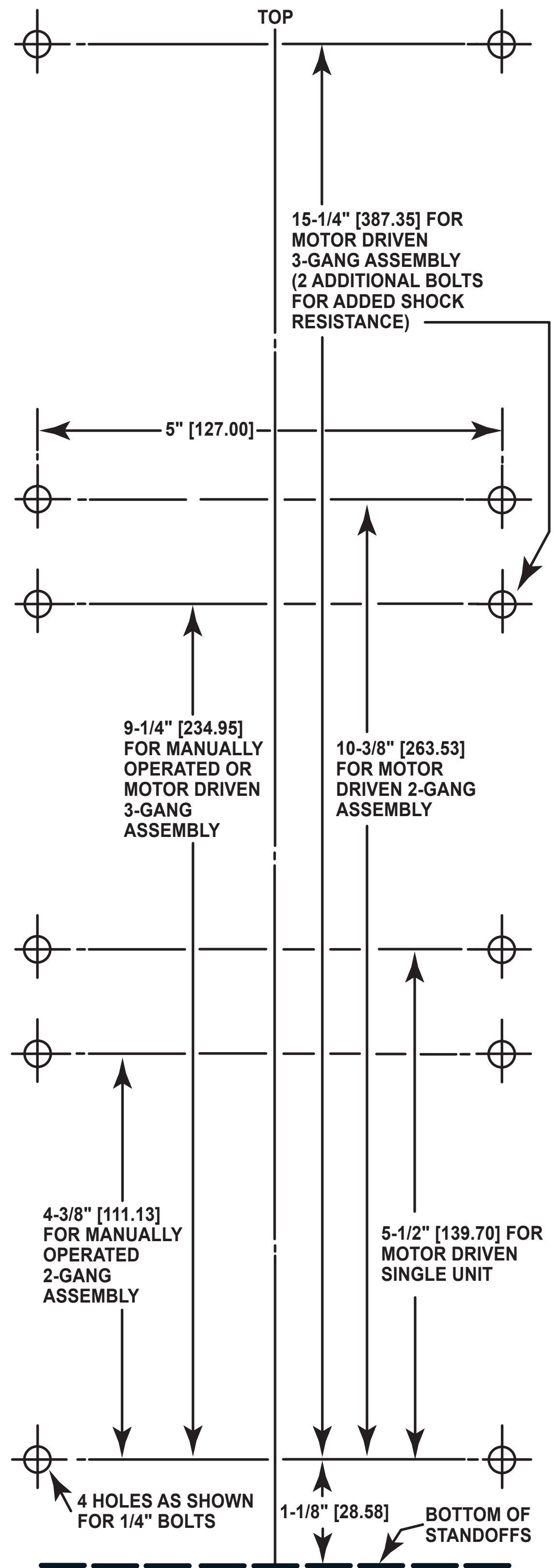

Please read important connection notes on other side.