

# SANZONATE™

## AQUAFLOW 3GPM

### OWNER'S MANUAL



REV. 1.0

# PRODUCT SPECIFICATIONS

Dimensions.....	15" x 6.5" x 16" (WxDxH)
Weight.....	15lbs 9.oz
Max. Input Water Pressure.....	85 PSI
Min. Input Water Pressure.....	40 PSI
Output Flow Rate.....	3.0 GPM (gallons per minute)
ORP.....	850mV [+/- 100mV]

## TABLE OF CONTENTS

INTRODUCTION. . . . .	3
SAFETY WARNINGS. . . . .	4
STATEMENT OF WARRANTY. . . . .	5
PRODUCT OVERVIEW. . . . .	6
INSTALLATION. . . . .	7 - 11
POWER. . . . .	12 - 13
OPERATING USAGE TIPS. . . . .	14
CHANGING THE AIR DRIER. . . . .	14 - 15
CLEANING THE INLET FILTER. . . . .	16 - 17
HOUR METER. . . . .	18
SAFETY DATA SHEET (SDS). . . . .	19 - 24

# INTRODUCTION

**Congratulations** on the purchase of your new AQUAFLOW 3GPM Fill Station!

Your machine was constructed with the highest level of precision and care. All new machines are rigorously inspected, tested and checked against our quality control checklist.

This manual will guide you through the installation of the equipment and provides answers to some common questions. Please read through this manual, paying careful attention to the Safety Warnings section. Keep in mind that any unnecessary damage, neglect or abuse of this machine will void your warranty. Should you have any questions regarding maintenance, replacing parts or ordering parts, please contact your authorized distributor.

If warranty questions should arise, contact your distributor for help.

Our mission is to eliminate harmful chemical consumption worldwide by developing innovative products that create an environmentally safe and renewable cleaning alternative.

Our AQUAFLOW 3GPM is an example of this; bringing a new dimension to traditional cleaning and purification.

This electronic device produces an aqueous ozone solution at concentrations ranging from 0.8 - 1.5 ppm, on a cold city water supply. This is suitable for filling floor cleaning equipment, mop buckets and other applications requiring a higher flow rate.

Sanzonate Global Inc., uses corona discharge ozone generators. Their output is calibrated at 700mg/hr @ 2.8 SCFH. This is higher than typical for ozone generators of this size!

# SAFETY WARNINGS

Always provide a copy of this manual to anyone using this equipment. There is a proper way to use this machine; training, although minimal, is recommended. Read this manual before operating this machine to prevent the possibility of personal injury to the operator or unintentional damage to the equipment.

- This machine produces an aqueous ozone solution and is intended for cleaning only, and the solution it generates may be used in place of most general-purpose cleaners.
- DO NOT put fingers or objects near the fan guard when the device is "ON."
- DO NOT disassemble this device. High voltage electricity exists inside this device while it is "ON." and failure to follow this precaution could result in electrical shock
- Power this device with the provided wall adapter only. It uses specific ratings for correct operation. The power requirement for this device can be summarized to 12v DC @ 10A. The power cord connects to the device with a 2.1mm plug.
- NEVER restrict OR block the flow of solution while the unit is "ON.". This machine was designed to operate with an open flow. Restricting or blocking its flow will cause water to back up into the ozone destruct chamber. Should this happen, it will need to be replaced for the machine to function properly.
- If you notice black droplets or stains underneath the machine REPLACE THE DESTRUCT TUBE and contact your distributor. \*Ozone gas cannot be destroyed if the destruct media gets wet.
- DO NOT LEAVE THE MACHINE RUNNING OVER-NIGHT. This can cause permanent damage to the ozone generators. A typical operating period should not last longer than one hour at a time, followed by at least 20 minutes of cool down time. Please contact your distributor with questions.

Consult this manual for troubleshooting help before reaching out to your sales representative or distributor. The "Troubleshooting" section addresses the most common issues. (Pg.19)

# STATEMENT OF WARRANTY

Sanzonate Global Inc. makes every effort to assure our products meet high quality and durability standards, and warrants to the original purchaser this product free from defects in materials and workmanship for the period of 365 days beginning on the date of purchase or order. Sanzonate Global Inc. in no event will be liable for injuries to persons or property, or for incidental and contingent, special or consequential damages arising from the use of our product. Neither Sanzonate Global Inc. nor any affiliate of Sanzonate Global Inc. shall be responsible to customer or others for lost revenues, lost profits, or other special, incidental, direct, indirect, or consequential damages or for loss or damage or other expenses directly or indirectly arising from customer(s), or any other person(s) use or inability to use Sanzonate Global Inc. product or for commercial loss of any kind. No recovery against Sanzonate Global Inc.. Whether in contract, tort (including negligence), strict liability or otherwise, shall be greater than the amount paid by the customer for any Sanzonate Global Inc. product.

Some states do not allow the exclusion or limitation of incidental or consequential damages, so the above limitation or exclusion may not apply to you.



# PRODUCT OVERVIEW

Take a moment to familiarize yourself with the unit. (Fig.1)  
Note the orientation of the inlet and outlet ports. (Fig.2)

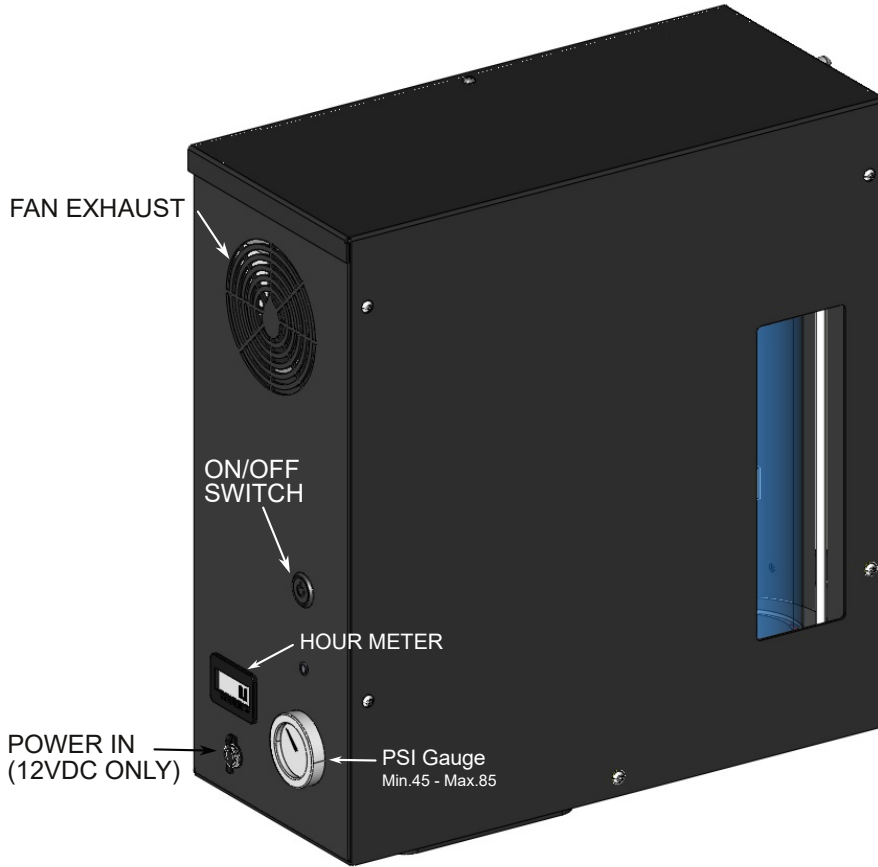

(Fig.1)

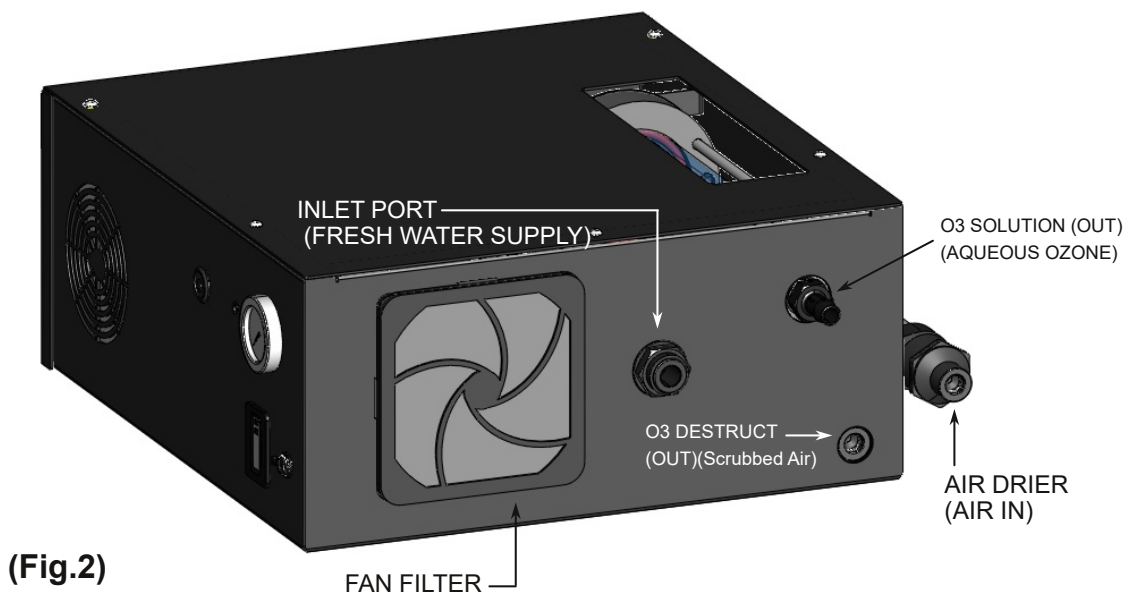

(Fig.2)

# INSTALLATION

This machine is intended for commercial use only.

Installations may not be identical to this manual.

If you need help or have questions contact your distributor.

## YOU WILL NEED:

Included: Screws | Plastic Anchors | Mounting Template | Liquid Level

Not Included:

- Tape
- Pencil/Pen

(For Drywall)

- 5/16" (8mm) Drill Bit
- Phillips screwdriver/drill

(For Concrete)

- 5/16" (8mm) Masonry Bit
- Hammer Drill
- Hammer or Mallet
- Phillips screwdriver/drill

Step 1: Determine the best suitable location for mounting your unit.

- Mount the unit a minimum of 4ft. above the floor
- And (preferably) within 4ft. (1.2m) of the electrical outlet intended to power the unit.

Step 2: Place a piece of tape on each top corner of the mounting template and secure the template against the wall. (Fig.3)

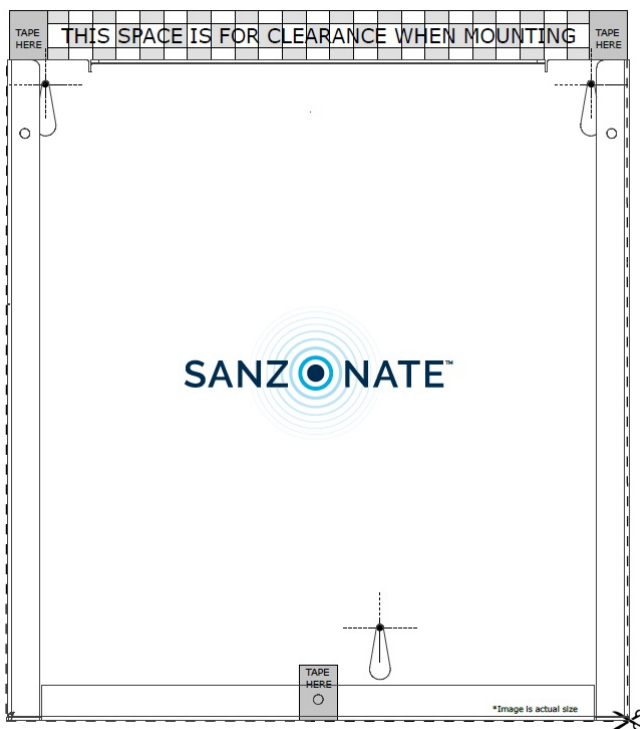

\*The tape can be rolled into a loop to make it double-sided.

Stick it to the back of the level, then stick the level to the top-center of the template. (Fig.3)

(Fig.3)

# INSTALLATION (con't)

Step 3: Drill the holes for the anchors.

Drywall:

- Use a 5/16" (8mm) drill bit on the three (3) marks.
- Remove the template from the wall.
- Lightly tap the anchors into each hole until they are flush against the wall.
- Start the screws [#10-32 x 1-1/4] by hand until you can switch to a screwdriver/  
drill to finish tightening. Stop when head is 1/4" (6.3mm) away from the wall.  
(Fig. 4)



(Fig.4)

Concrete:

- Use a 5/16" (8mm) masonry drill with a hammer drill and drill holes on the three (3) marks.
- Remove the template from the wall.
- Lightly tap the plastic anchors into each hole until they are flush against the wall.
- Start the screws [#10-32 x 1-1/4] by hand until you can switch to a screwdriver/drill to finish tightening. Stop when the screw head is 1/4" (6.3mm) off the wall (Fig.4).

Step 4: Hang the machine over the screw heads while aligning with the keyholes on the back of the machine.

- It should hang tight against the wall.
- If necessary, remove the unit and slightly tighten the screws, re-fitting until it's snug.



# INSTALLATION (con't)

Step 5: Connect the water filter (Fig. 5) to the INLET port located in the middle of the unit. (Fig. 6) & (Fig.7)

Arrows located on the side of the filter point in the direction of water flow. When installed the arrows should point UP (↑).

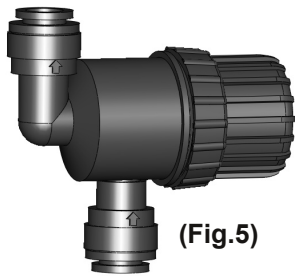

(Fig.5)

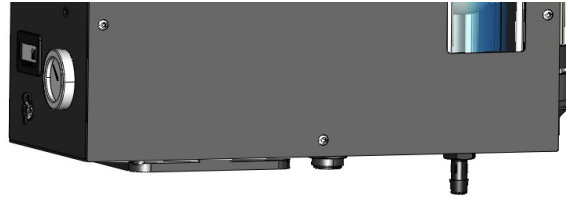

(Fig.6)



(Fig.7)

# INSTALLATION (con't)

Step 6: Connect the 6ft black tubing into the bottom of the filter. (Fig. 8)

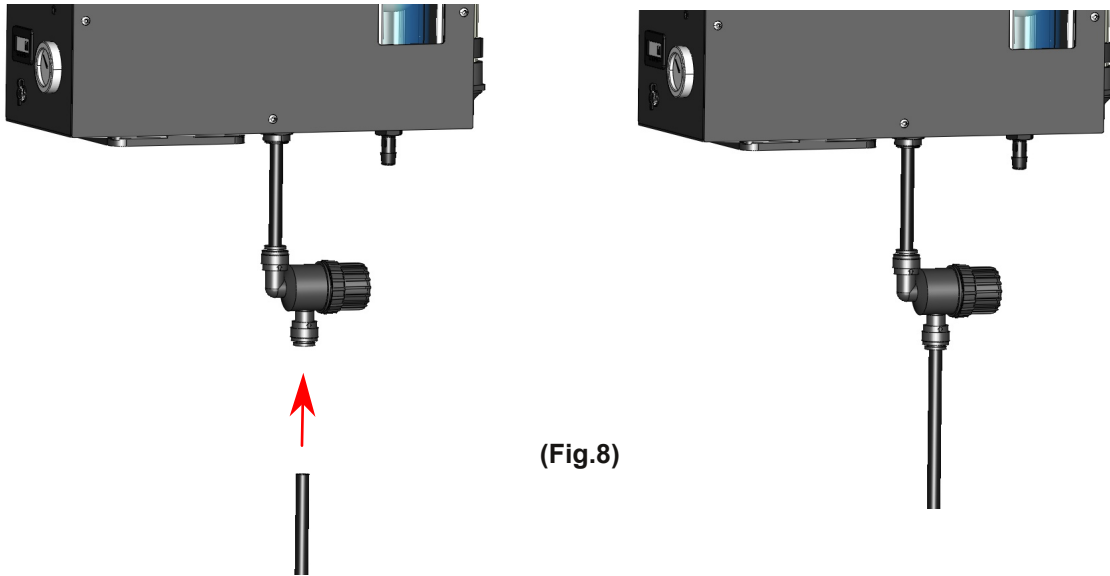

Step 7: Connect the white adapter to the cold water supply. (provided) (Fig.9)  
A 3/4" garden faucet is a common connection point. (Fig.10)  
The remaining end of black tubing connects this tube port.  
Slowly, turn ON the water supply.  
If you have a different style faucet or need assistance, contact your distributor.

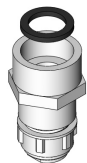

(Fig.9)

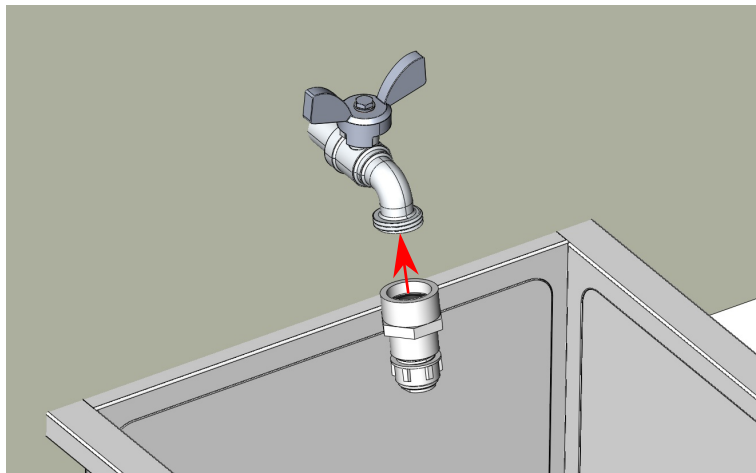

(Fig.10)

The inlet adapters come with only 1 black washer. You might find that you need to install a second. Please contact your distributor for assistance.

# INSTALLATION (con't)

- Step 8: Connect the blue hose to the black hose barb fitting on the bottom-right of the 3GPM. Slide the hose onto the barb with a slight twisting motion. (Fig.11) There is very little pressure in the blue solution hose; a clamp is not needed. (Fig.12)

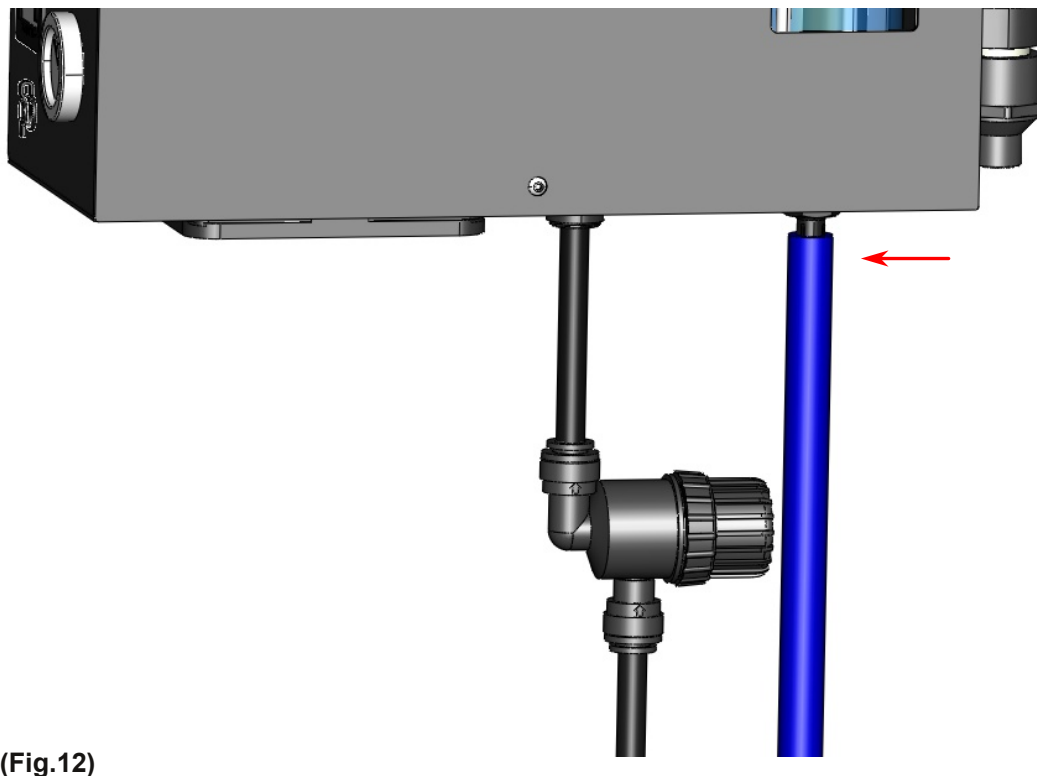
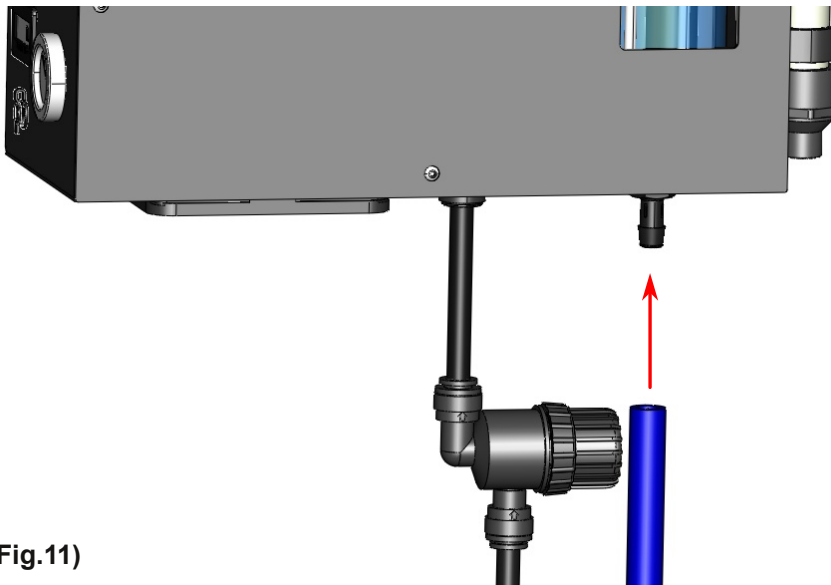

# POWER

The AQUAFLOW 3GPM uses an AC/DC Adapter (Power Supply) to convert mains voltages into 12VDC.

Step 9: Connect the 3-prong male end into a wall outlet, preferably a GFCI.  
(Fig.13)

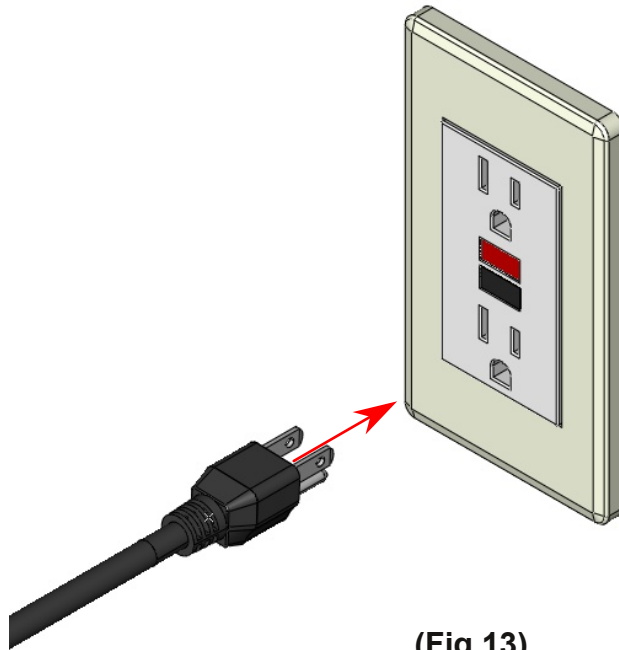

(Fig.13)

Step 10: Connect the female end into the AC/DC adapter. (Fig.14)

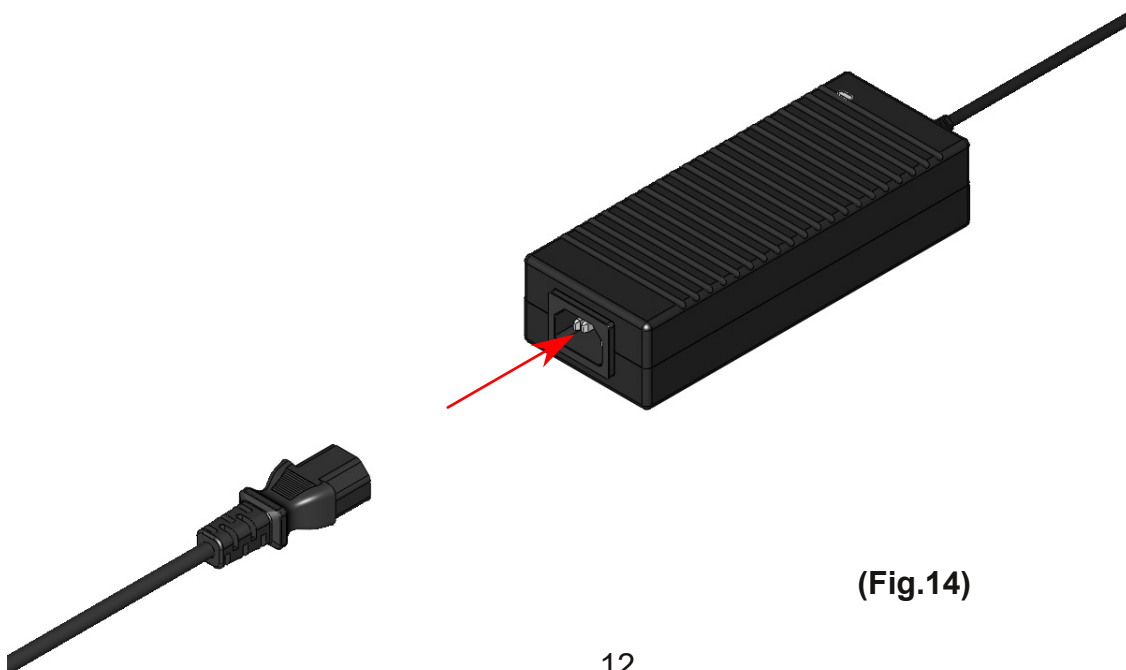

(Fig.14)

# POWER (con't)

Step 11: Verify the blue LED on the 12V adapter is illuminated. (Fig.15)

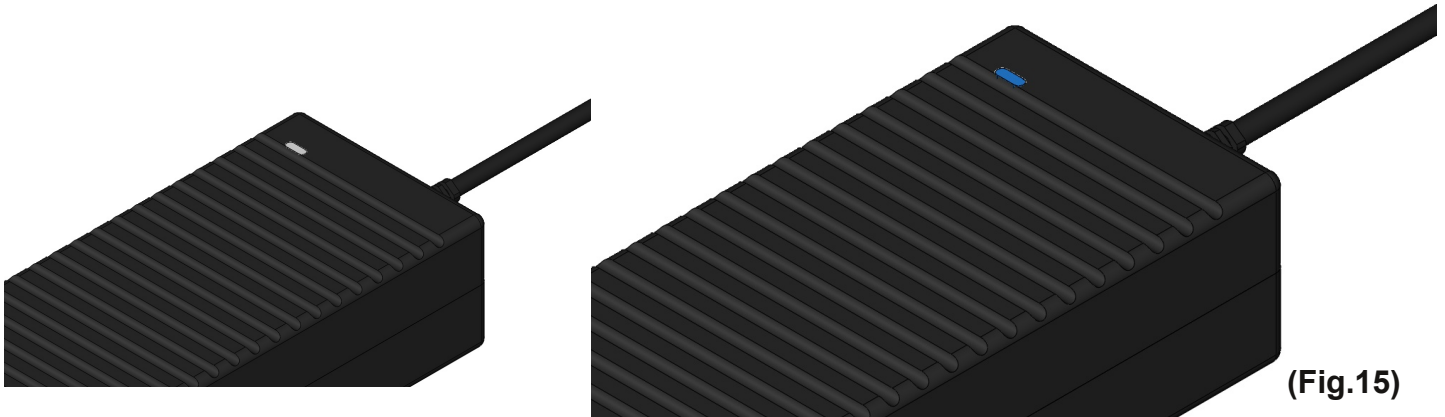

NOTE: If the blue LED does not illuminate, contact your sales representative for assistance.

Step 12: Connect the barrel jack from the power adapter into the power port located on the lower-left side of the unit. (Fig.16)

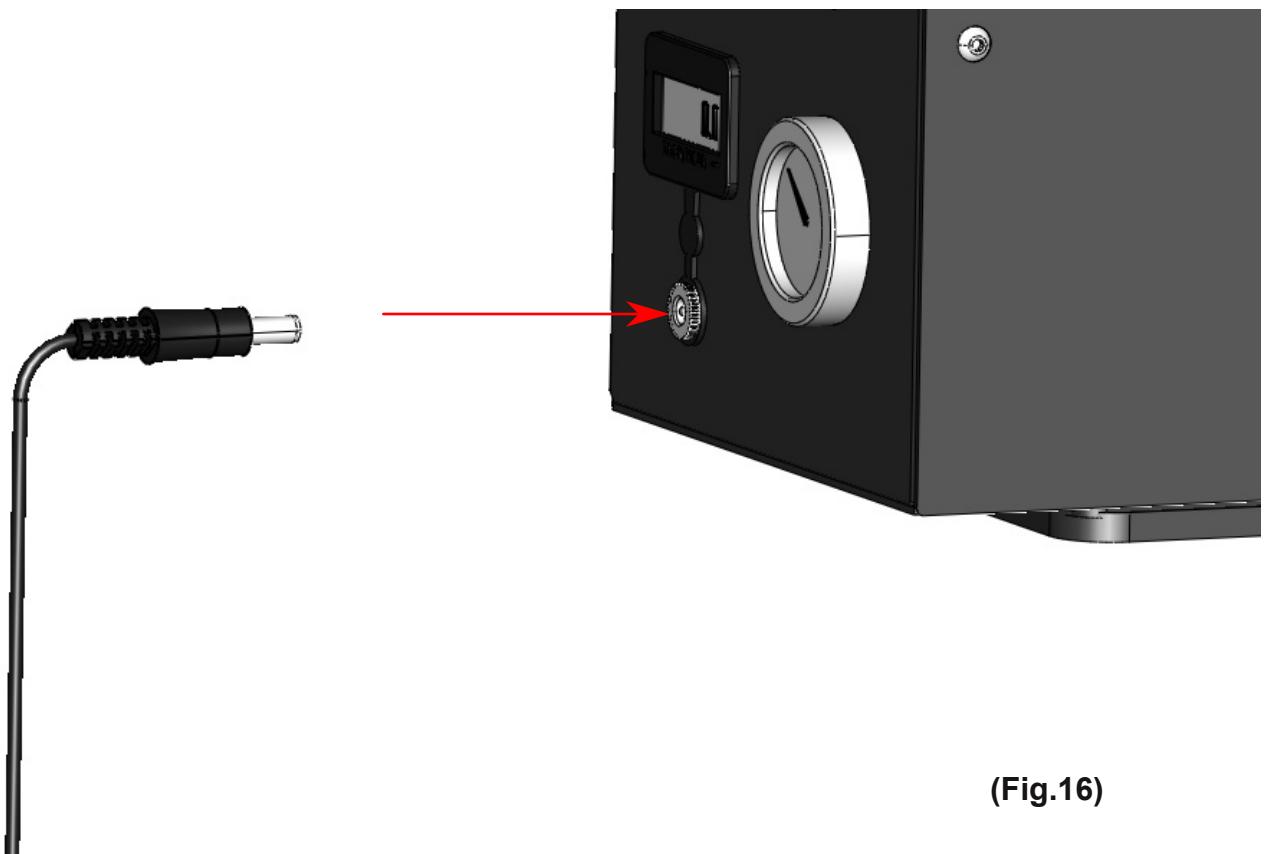

# OPERATING USAGE TIPS

Great job! You are finished with the installation and may begin using your NEW AQUAFLOW 3GPM!

To Use: Press-in the ON/OFF button located on the left side of the unit. (Fig.17)

A BLUE light will illuminate inside the viewing window.

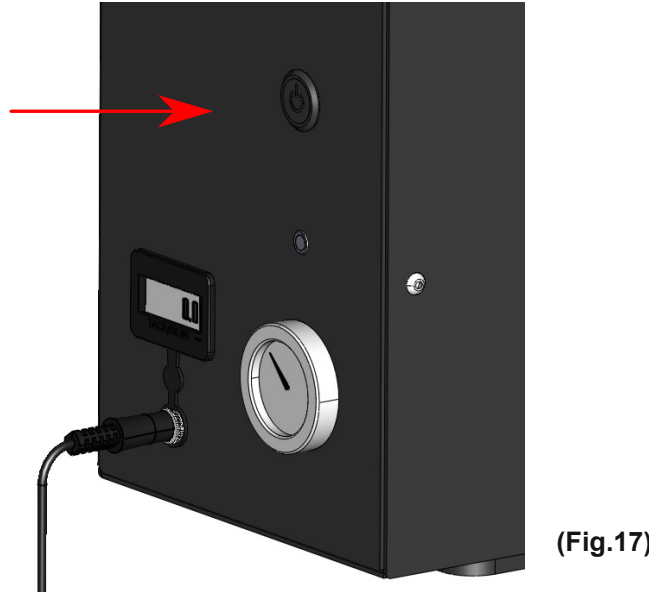

## CHANGING THE AIR DRIER

**The Air Drier:** The AQUAFLOW 3GPM uses the most advanced drying media to filter the air before entering the ozone generators.

This media is hydro-absorbent, soaking up microscopic particles of water from the incoming air while filtering out dust.

1. Disconnect the tubing from the air drier. (Fig.18A)
2. Hold the top of the air drier, while pulling away from the 3GPM unit. (Fig.19) & (Fig.20)
3. Discard the old air drier.
4. Remove the new air drier from packaging.
5. Peel the "REMOVE" sticker from the bottom of the drier and pull off the green cap.
6. Place one hand on the opposite side of the 3GPM to help counter push the new air drier into the clips.
7. Insert the new drier at an angle to ensure the bottom clip is the first to get secured. (Fig.21)
8. Push firmly until the second, top clip is secured. Slide the drier down until it touches the top clip.
9. Reconnect the tubing to the hose barb on top of the new air drier.

# CHANGING THE AIR DRIER (con't)

- To prevent damage to the 3GPM, never replace the air drier while the unit is "ON".
- Extra tubing has been included inside the machine, do not be afraid to use it. You may gently pull out some tubing to assist with the replacement. Try not to pull more than 2.0" total. Be sure to gently push the tubing back into the machine when finished.
  - There should be a nice smooth bend in the tubing without any kinks or folds.(Fig.18B)
  - The cap on top of the air drier should be resting on the top of the top holding clip.(Fig.18C)

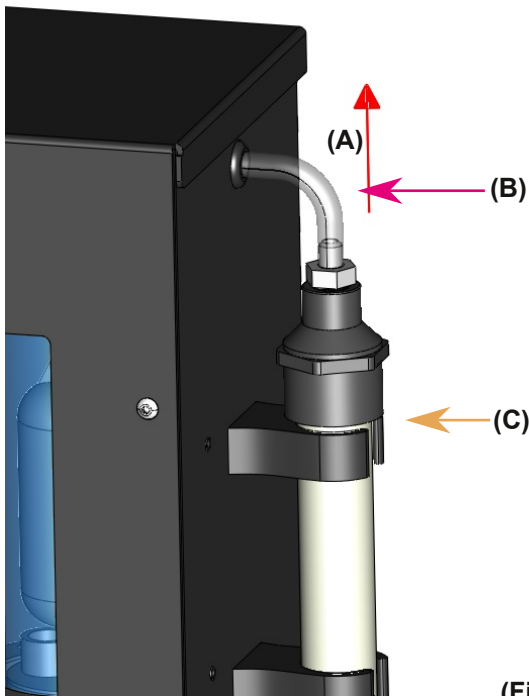

(Fig.18)

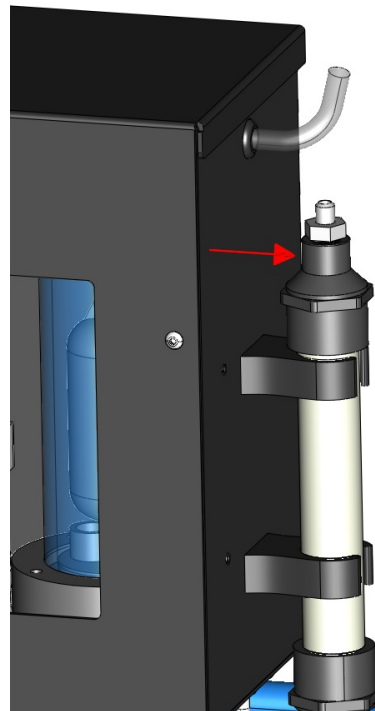

(Fig.19)

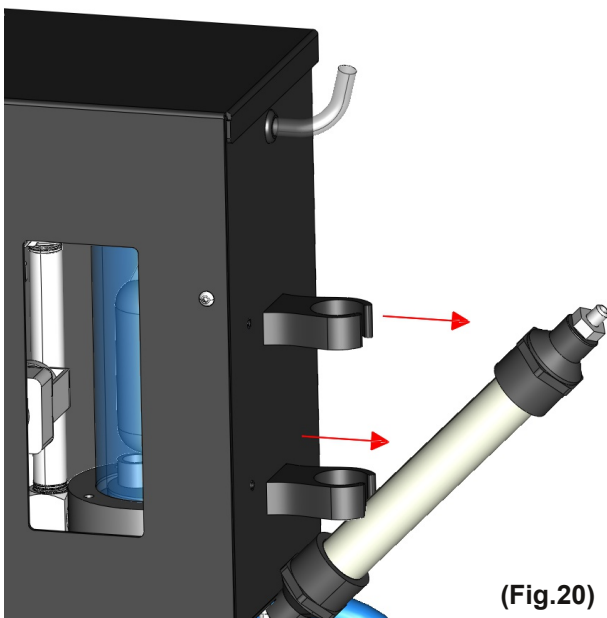

(Fig.20)

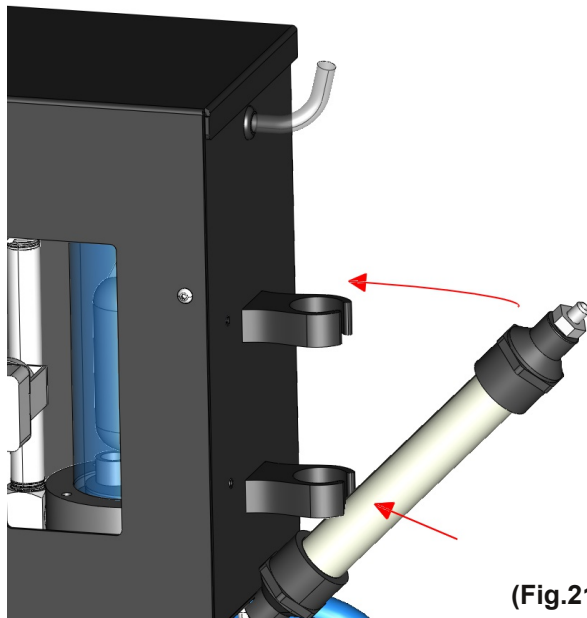

(Fig.21)

# CLEANING THE INLET FILTER

A 100 mesh (150 microns) inlet water filter is used to prevent foreign objects from obstructing the flow of solution inside your 3GPM. Keeping the filter screen clean will help prevent unnecessary maintenance issues and prolong the life of your equipment.

We recommend after the first week from installation the screen inside the inlet water filter should be inspected. Early inspections allow you to assess the quality of the source water which will help determine the best maintenance schedule:

- If the filter is clean, continue inspections every 3-months.
- If the filter needs to be cleaned, you will want to perform inspections more frequently (weekly) and might want to consider a larger pre-filter to be installed ahead of the 3GPM.

## To Clean:

- Locate the water source and temporarily turn it, "OFF".
- Release pressure by briefly, turning powering "ON", to "OFF".
- Place a cup under the filter cap; there will be some water.
- Unscrew the filter cap from the main body. (Turn Left)(Fig.22)
- Pull the blue screen out to inspect it for rocks or mud. (Fig.23)
- If dirty, rinse the screen under a faucet with running water.

## Reassembly:

- Align the raised ring on the inside-bottom of the filter cap with the opening on the bottom of the blue filter screen.
- Re-install the screen and cap. (Turning Right).  
DO NOT USE TOOLS to tighten the cap. Hand tighten only.
- Slowly turn ON the supply water valve.
- Check for leaks.
- Done.



# CLEANING THE INLET FILTER (CON'T)

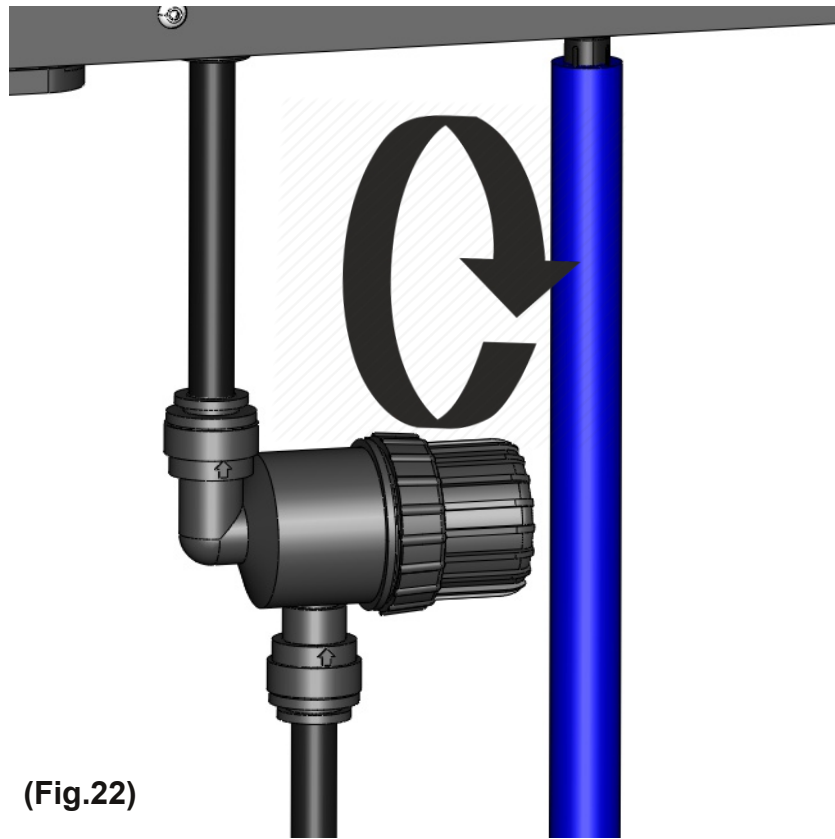

(Fig.22)

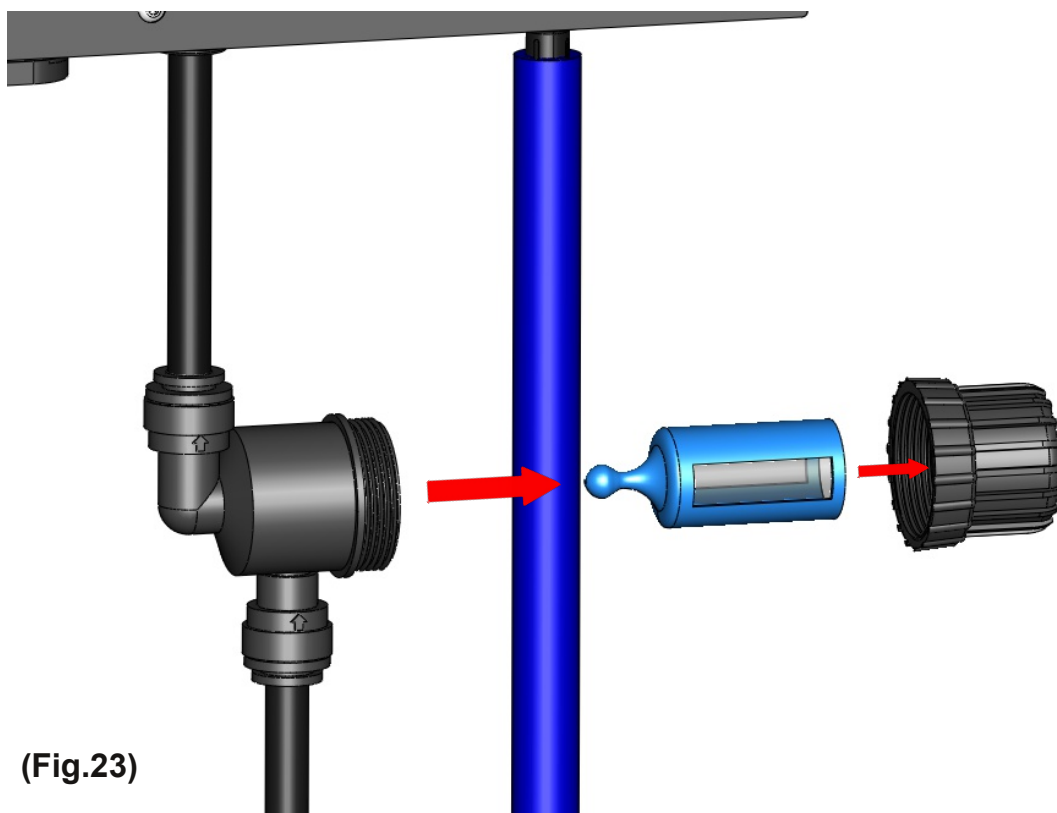

(Fig.23)

# HOUR METER

The hour meter is Non-Resettable.

A digital hourglass will flash on the screen while in operation.

**Display Resolution:** While the total running hours is in range  
0.0 - 9999.9H the resolution is 0.1H  $\approx$  6m  
After the total running hours pass 10000H  
the resolution changes to 1H  $\approx$  60m.

**Change Filter Notification:** "CLEAN AIR FILTER", "NOW"

The hour meter has been programmed to display an alert message indicating that it is time to replace the air drier. The setpoint for the alarm starts at 400H and counts down.

Main interface--Displays the total working hours.



Pressing the button once displays countdown alarm total

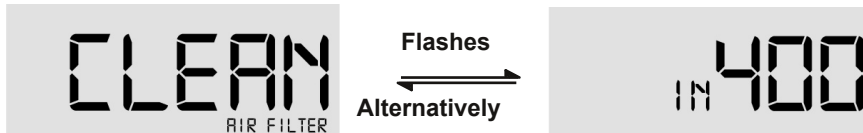

**Alarm Screen**

When the countdown reaches 0H, "CLEAN AIR FILTER" & "NOW" will flash back and forth. Press and hold the button on the front of the hour meter for 5s to clear the reminder alarm and reset the timer to 400H.

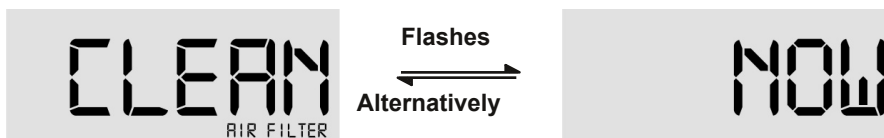

Pressing and holding the button for 10s will reset the countdown alarm total to 400H.



# Sanzonate Global, Inc. Aqueous Ozone Solution

## Safety Data Sheet

according to the federal final rule of hazard communication revised on 2012 (HazCom 2012)

Date of issue: 06/01/2022

Revision date: 03/01/2023

Printed:03/01/2023 Version: 4.0

### SECTION 1: Identification of the substance/mixture and of the company/undertaking

#### 1.1. Product identifier

Product name : Sanzonate Global, Inc. Aqueous Ozone Solution  
Product code : n/a

#### 1.2. Relevant identified uses of the substance or mixture and uses advised against

Use of the substance/mixture : For professional use only  
Disinfectant/  
Antimicrobial/Surface  
Cleaning

Use advised against : None identified

#### 1.3. Details of the supplier of the safety data sheet

SANZONATE GLOBAL INC.  
12020 Shamrock Plaza Suite  
200 Omaha, NE 68154

Tel: 1-855-424-6723

#### 1.4. Emergency telephone number

Emergency number : (1-855-424-6723 - 24 HOURS)

### SECTION 2: Hazards identification

#### 2.1. Classification of the substance or mixture

##### Classification

Not Classified

#### 2.2. Label elements

##### Labelling

No labelling applicable

#### 2.3. Other hazards

No additional information available : None known

#### 2.4. Unknown acute toxicity

Not applicable

### SECTION 3: Composition/information on ingredients

#### 3.1. Substances

Not applicable

#### 3.2. Mixture

This mixture does not contain any substances to be mentioned according to the criteria of section 2.2 of HazCom 2012. Dissolved ozone gas in water 0 to 2.0 ppm.

§ The signal word, warning, is required under OSHA Hazards Communication Standard, 29 CFR 1910.1200, and is not meant to represent EPA pesticide labelling under FIFRA.

# Sanzonate Global, Inc. Aqueous Ozone Solution

## Safety Data Sheet

according to the federal final rule of hazard communication revised on 2012 (HazCom 2012)

### SECTION 4: First aid measures

---

#### 4.1. Description of first aid measures

- First-aid measures after inhalation : Inhalation of aqueous ozone may lead to irritation of the lungs. If breathing is difficult, remove victim to fresh air and keep at rest in a position comfortable for breathing. If exposure symptoms persist, seek medical advice.
- First-aid measures after skin contact : Not known to cause irritation, but if skin irritation occurs, wash well with fresh water. If skin irritation persists, seek medical attention.
- First-aid measures after eye contact : If eye irritation occurs with exposure to aqueous ozone, it is suggested to efficiently rinse eye with potable water for 5 minutes. Remove contact lenses, if present and easy to do. Continue rinsing. If eye irritation persists: Get medical advice and attention.
- First-aid measures after ingestion : No specific measures have to be taken if the product is swallowed.

#### 4.2. Most important symptoms and effects, both acute and delayed

Not known to be harmful to health in normal use.

#### 4.3. Indication of any immediate medical attention and special treatment needed

Treat symptomatically.

### SECTION 5: Firefighting measures

---

#### 5.1. Extinguishing media

Suitable extinguishing media : Use fire-extinguishing media appropriate for surrounding fire.

Unsuitable extinguishing media : None to our knowledge.

#### 5.2. Special hazards arising from the substance or mixture

None known.

#### 5.3. Advice for firefighters

Firefighting instructions : No special requirements.

Protective equipment for firefighters : No additional risk management measures required.

Other information : NA

### SECTION 6: Accidental release measures

---

#### 6.1. Personal precautions, protective equipment and emergency procedures

General measures : Spilled material may present a slipping hazard.

#### 6.2. Environmental precautions

None known.

#### 6.3. Methods and material for containment and cleaning up

Methods for cleaning up : Allow the residual product to evaporate. No special procedures required.

#### 6.4. Reference to other sections

For further information refer to section 8: Exposure-controls/personal protection. For disposal of residues refer to section 13: Disposal considerations.

# Sanzonate Global, Inc. Aqueous Ozone Solution

## Safety Data Sheet

according to the federal final rule of hazard communication revised on 2012 (HazCom 2012)

### SECTION 7: Handling and storage

---

Precautions for safe handling : Aqueous ozone solution should not be sprayed as an aerosol to avoid the release of ozone gas out of aqueous ozone solution. The decay rate of ozone gas is related to temperature and organic material exposure. Testing has proved that the rate of ozone gas released from aqueous ozone solution is below the PEL established by OSHA for gaseous ozone. Avoid extended periods of use in confined areas without proper ventilation.

#### 7.1. Conditions for safe storage, including any incompatibilities

Storage conditions : No special measures required.

Incompatible materials : Natural rubber components may degrade or dry-out over time with extended use.

Maximum storage period : 3 year If stored indoors with no direct sunlight or wide temperature swings, the storage period may be extended to 5 years.

#### 7.2. Specific end use(s)

No additional information available

### SECTION 8: Exposure controls/personal protection

---

#### 8.1. Control parameters

No additional information available

#### 8.2. Exposure controls

Appropriate engineering controls : Handle in accordance with good industrial hygiene and safety procedures.

Personal protective equipment : No special equipment needed under normal conditions.

# Sanzonate Global, Inc. Aqueous Ozone Solution

## Safety Data Sheet

according to the federal final rule of hazard communication revised on 2012 (HazCom 2012)

### SECTION 9: Physical and chemical properties

---

#### 9.1. Information on basic physical and chemical properties

Physical state	: Liquid
Color	: Colorless
Odor	: Fresh
Odor threshold	: No data available
pH	: No data available
Relative evaporation rate (butyl acetate=1)	: = 1
Melting point	: No data available
Freezing point	: No data available
Boiling point	: 100 °C (212 °F)
Flash point	: No data available
Auto-ignition temperature	: Not applicable
Decomposition temperature	: No data available
Flammability (solid, gas)	: Not applicable
Vapor pressure	: 2.3 kPA (20 °C)
Relative vapor density at 20 °C	: 0.62
Relative density	: No data available
Solubility	: Water: completely soluble
Log Pow	: No data available
Log Kow	: No data available
Viscosity, kinematic	: No data available
Viscosity	: No data available
Explosive properties	: No data available
Oxidising properties	: No data available
Explosive limits	: No data available

#### 9.2. Other information

No additional information available

### SECTION 10: Stability and reactivity

---

#### 10.1. Reactivity

No dangerous reactions known under normal conditions of use.

#### 10.2. Chemical stability

Stable.

#### 10.3. Possibility of hazardous reactions

No dangerous reactions known.

#### 10.4. Conditions to avoid

None under normal conditions.

#### 10.5. Incompatible materials

Natural rubber components may degrade or dry-out over time with extended use.

#### 10.6. Hazardous decomposition products

None known.

### SECTION 11: Toxicological information

---

#### 11.1. Information on toxicological effects

Acute toxicity : Not classified  
(Based on available data, the classification criteria are not met)

# Sanzonate Global, Inc. Aqueous Ozone Solution

## Safety Data Sheet

according to the federal final rule of hazard communication revised on 2012 (HazCom 2012)

Skin corrosion/irritation	: Not classified (Based on available data, the classification criteria are not met)
Serious eye damage/irritation	: Not classified
Respiratory or skin sensitization	: Not classified
Germ cell mutagenicity	: Not classified (Based on available data, the classification criteria are not met)
Carcinogenicity	: Not classified (No carcinogen substances in IARC, NTP or OSHA cited.)
Reproductive toxicity	: Not classified (Based on available data, the classification criteria are not met)
Specific target organ toxicity (single exposure)	: Not classified (Based on available data, the classification criteria are not met)
Specific target organ toxicity (repeated exposure)	: Not classified (Based on available data, the classification criteria are not met)
Aspiration hazard	: Not classified (Based on available data, the classification criteria are not met)

## SECTION 12: Ecological information

---

### 12.1. Toxicity

Ecology - general : No additional information available

### 12.2. Persistence and degradability

No additional information available

### 12.3. Bioaccumulative potential

No additional information available

### 12.4. Mobility in soil

No additional information available

### 12.5. Other adverse effects

Effect on ozone layer : No additional information available

Effect on the global warming : No additional information available

# Sanzonate Global, Inc. Aqueous Ozone Solution

## Safety Data Sheet

according to the federal final rule of hazard communication revised on 2012 (HazCom 2012)

### SECTION 13: Disposal considerations

#### 13.1. Waste treatment methods

Waste disposal recommendations : May be disposed of in household waste landfill.

Waste disposal recommendations- Containers : NA

### SECTION 14: Transport information

#### In accordance with DOT

Not regulated for transport

#### Additional information

Other information : No supplementary information available.

#### Transport by sea

Not regulated for transport

#### Air transport

Not regulated for transport

### SECTION 15: Regulatory information

#### 15.1. US Federal regulations

EPA/FIFRA (U.S. Environmental Protection Agency/Federal Insecticide, Fungicide, and Rodenticide Act) Regulates ozone generators and their distribution, sale, and use under their device program (includes sanitation by such devices and the conversion of potable water)

#### 15.2. International regulations

No additional information available

#### 15.3. US State regulations

No additional information available

### SECTION 16: Other information

NFPA health hazard/  
fire hazard/reactivity : 0 - Normal Material; Exposure under fire conditions would offer no hazard. 0 - Will not burn. 0 - Stable Material. No Specific or Special Hazard.

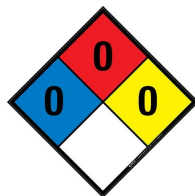

Last Revision date 03/01/2023

#### Clean Air Act | US EPA

This product does NOT contain any hazardous air pollutants (HAP), as defined by the U.S. Clean Air Act Title I, Section 112, U.S. Code 7412

#### Clean Water Act | US EPA

This product does NOT contain any hazardous substances or toxic pollutants, as defined by the Clean Water Act (CWA) and CERCLA, Section 311(b)(2)(A), Table 116.4 and 116.4B

*The information provided in this Safety Data Sheet is correct to the best of our knowledge, information, and belief at the date of its publication. The information given is designed only as a guidance for safe handling, use, processing, storage, transportation, disposal and release and is not to be considered a warranty or quality specification. The information relates only to the specific material designated and may not be valid for such material used in combination with any other materials or in any process, unless specified in the text.*